

COMPUTER PROGRAM FOR SINGLE SAMPLING PLANS FOR VARIABLES, WITH STANDARD DEVIATION UNKNOWN

EFTIMIE Nicolae
 "Transilvania" University of Braşov
 eftimien@unitbv.ro

Keywords: Acceptance sampling, Single sampling plans for variables, Sigma unknown

The paper presents a computer program for the single sampling plans for variables, for the case when the standard deviation σ is unknown. At the beginning, the program calculates the values of k and n .

In order to make the decision about the quality of the lot, in the case when σ is unknown and the quality characteristic has two specification limits, the program calculates the value of MSD according to the method presented in [1] (Figure 1).

Using the sample's measurements, the program performs the necessary calculations and makes the decision about the quality of the lot (Figure 2).

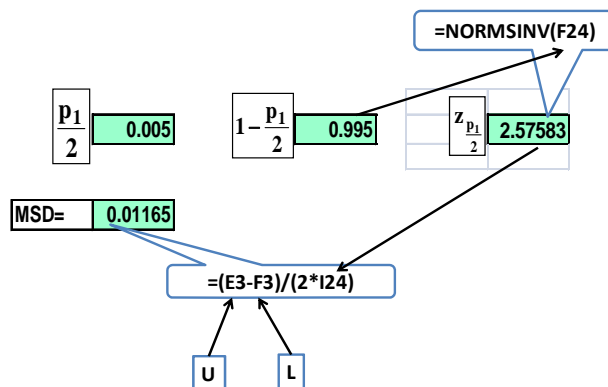

Figure 1. The calculation of MSD

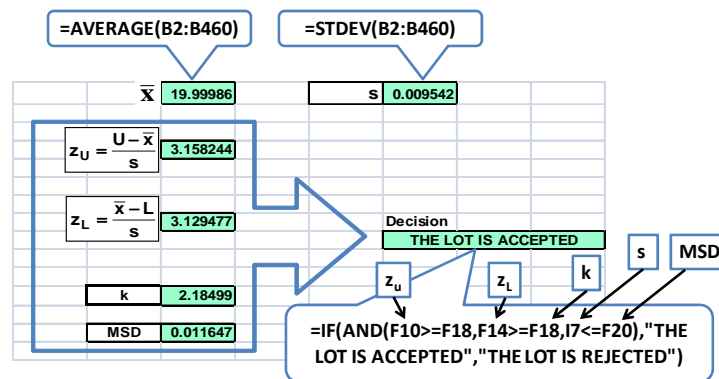

Figure 2. The decision about the quality of the lot

REFERENCES

1. Duncan, A. Quality Control and Industrial Statistics. Richard D. Irwin Inc., Homewood, Illinois, 1974, pp. 268-278, ISBN 0-256-01558-9.
2. *** Microsoft Excel 2007 Help