

MODEL OF A DEVICE FOR INPUT OF 2D GRAPHIC INFORMATION IN COMPUTER MEDIUM

ILARIONOV Rajcho

Technical University of Gabrovo, Bulgaria

ilar@tugab.bg

The article proposes a model of a device for input of graphical information in computing environment. This approach is founded on the use of the electromagnetic induction method. Analytical conclusions are presented for forming coordinates X and Y, as well as the error that can result from the linear interpolation. The mathematical model presented above is suitable for producing real devices with good technical parameters. In case of technological production of small formats (up to A3), it is recommended that the pointing device (the coil) be an inductor, and the work table – a receiver. In case of larger formats the opposite arrangements is preferred, because greater current ($I_m \sin \omega t$) can flow along the long lines of the work table, which will induce the required magnetic field. Applying this approach, three real digitizers have been developed – format A0, A3 and Tablet (11x11 in.). A resolution of 0.025 mm and an accuracy of 0.1 mm have been achieved.

Electromagnetic digitizers cannot input graphical information that is represented on originals having an insert of aluminum or another metal, such as topological maps, etc. This is a drawback that cannot be overcome, because the metal part between the sensor and the work table acts as a screen of the magnetic field.

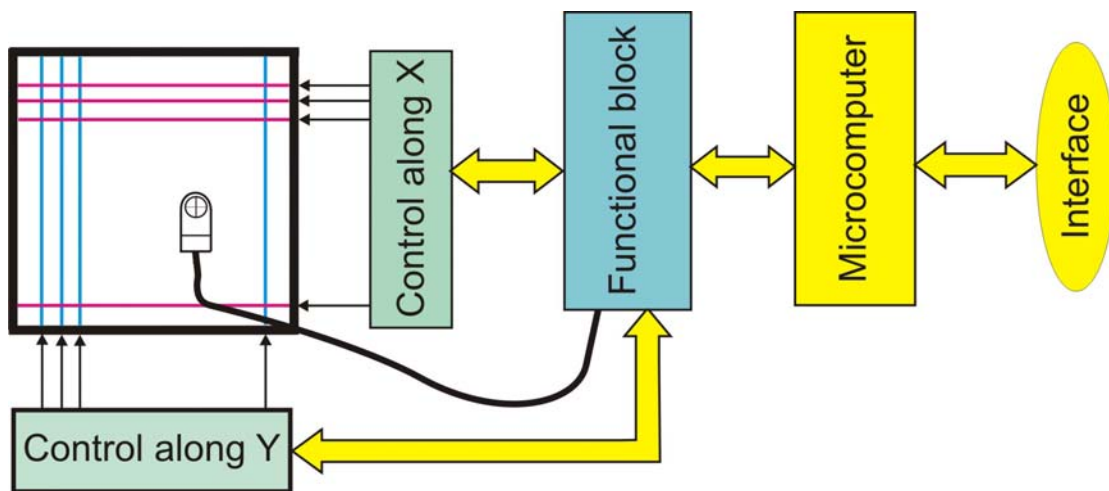

Fig. 1. Electromagnetic digitizer.

REFERENCES

- [1] Ilarionov, R. Computer Peripherals, second edition G, Vasil Aprilov University Publishing House, 2008.
- [2] Cook, B. & N. White. Computer Peripherals. Edward Arnold, London 1995.
- [3] Valchev, T., Hr. Hristov. Input/Output Devices for Computer Graphics S., Tehnika, 1987.