

MODERNIZING OF THE PRESSURE REGULATORS FROM THE RESPIRATORY CIRCUIT OF HYPERBARIC CHAMBER AT DIVING CENTER (Mechanic)

STANCIU Tamara, RUS Simona, DIACONU Mihai

“Diving center” Constanța

tamarastanciu@yahoo.com

Keywords: respiratory, mask regulator, dump valve, pressure limiter, back pressure regulator

A hyperbaric chamber includes more pneumatic installations as Breathing and dumping circuit which has more types of pressure regulator: mask regulator, dump valve, pressure limiter and back pressure regulator.

1. The mask regulator reduces the pressure of the breathing gas from the medium pressure (MP) level at manifold of the command rack to the ambient pressure into the hyperbaric chamber. This is an individually component of the diver mask ensemble.
2. The dump-valve is located on the pneumatic circuit, behind the mask regulator and it is an individually apparatus too. It determinates the controlled exit of the expired gas at a small pressure than the regulator's back pressure. The limit of the dump-valve is 6 bar precinct pressure
3. The pressure limiter is designed to extend the utilization of the dump-valve over 6 bar precinct pressure.
4. The back pressure regulator makes the dump-valve and the pressure limiter too functions. It extends the safety of gas exhalation from the mask to the outside, by gradually reducing of the pressure from 450 msw (45 bar) to atmospheric value (1 bar).

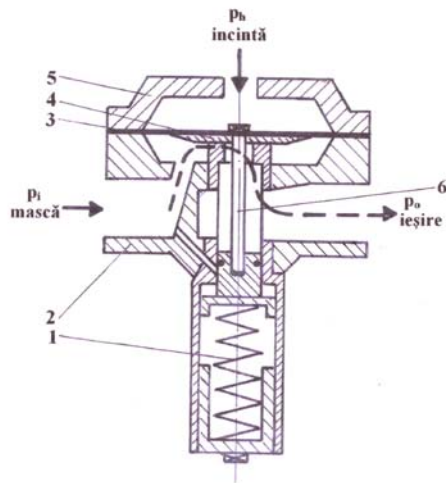

Bibliography:

- [1] Dumitru D., Vlad C., *Divers and underwater vehicles*, 1986, Scientific and Encyclopaedic Ed. , București.
- [2] Degeratu M., Petru A., Ioniță S., *The diver's manual*, 1999, Per Omnies Artes Ed., București.
- [3] Degeratu M., Petru A., Ioniță S., *The diver's guide*, 1992, Olimp Press Ed. , București.