

# THE TESTING SET AT THE TWO CNC AXES ROTARY-TILTING TABLE MRI 500-2CNC

GANEA Olimpiu<sup>1</sup>, MIHAILA Ioan<sup>2</sup>, HORGE Ioan<sup>3</sup>, GANEA Macedon<sup>4</sup>  
1&3. Stimin Oradea, 2&4. University of Oradea,

**Keyword:** Table testing set

The rotary-tilting table with the diameter of 500 mm is presented by the authors in the present paper work, regard the testing set according to the international standards about the quality in the field of five axes machining concept. The 2 axes rotary tilting table MRI 500-2CNC is an independent module, usable at different machine tool types, including FPH1000CNC, FPM1000CNC and others in the variants as CNC machine or machining center, in order to extend the technical level to the five axes machining technology.

The strong conditions of the working need adequate solutions for the feed mechanisms.

The feed chain is based on parallel mechanisms, synchronous and preloaded, in order to obtain the dynamic features.

The main testing set is established according to the international standards: ISO 230-1, ISO 230-2, VDI 3441DGQ, ASME B5-52-1992, and others.

The testing set contains the checking about: the geometrical precision, the cinematic precision, the dynamic stability, the working precision, the TCPM accuracy, the load capacity, etc. The paper work presents the checking methods, the devices, the permissible values.

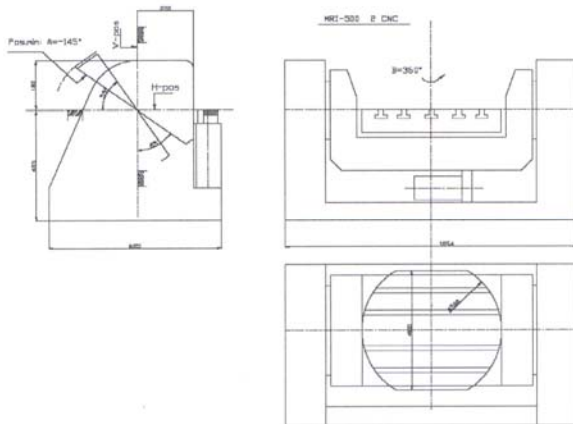

## BIBLIOGRAPHY:

- [1] - Olimpiu GANEA<sup>1</sup>, Ioan MIHAILA<sup>2</sup>, Ioan HORGE<sup>3</sup>, Macedon GANEA<sup>4</sup>; (1&3. eng. Stimin Oradea, PhD student, 2&4. PhD professor University of Oradea), **THE CINEMATIC CHAIN OF TWO CONTINUOUS AXES ROTARY-TILTINGTABLE MRI 500-2 CNC AT THE MACHINE "CPFPH 1000-5 axes"**, Ses. de com. st., Univ. din Oradea, 2008