

# OPTIMIZATION OF THE PLASTICIZING UNIT CONSTRUCTION

GRAMA Lucian<sup>1</sup>, VASILACHE Virgilius<sup>2</sup>

<sup>1</sup>“Petru Maior” University of Târgu – Mureș Romania, <sup>2</sup> Electrocentrale S.A. Romania

**Keywords:** Machine elements, Finite Element Method, Plastics Injection Machinery

The plasticizing unit is the most important part of an injection molding machine. The related to this issue concerns of our company were materialized in a new plasticizing unit, with new technical solutions. (patented RO – 99019 and RO – 99128). The injection torpedo has an original geometry fulfilling both the task of intensive mixing and the task of a one-way valve. By means of finite element method calculations, we developed a new geometry of the torpedo, avoiding the maintenance problems which occurred all the time when using the old solution.

We designed a special tip of the feeding screw in order to avoid this problem. Picture 2 shows a plunger zone (a) to the frontal end of the screw (1), which zone fits with the plasticizing cylinder (2). There is a gap between the end of the screw spiral and the plunger zone, 4 equidistant holes (A) being performed on the circumference of the gap area. The 4 holes are inclined related to the longitudinal axle of the screw and all of them are bundled in a central axial hole (B) where a ball (3) and a pin (4) are located. The plasticized material is pushed forward in the gap area between the end of the spiral and the plunger zone by the forces appearing in its mass when the screw rotates. The plasticized stream is spread in the 4 inclined holes (A) and then enters in the central axial hole (B) reunifying and pushing the ball until this one hits the pin. The stream is divided again around the ball reunifying after over-passing the ball. The screw pushes forcefully forward during the phase of injection and a pressure appears in the material located in front of the screw due the plunger zone.

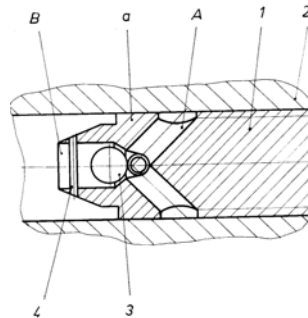

Picture 2 The new solution

## REFERENCES

- [1] XXX: **ANALIZA EXPERIMENTALĂ A TENSIUNILOR**, Editura Tehnică, București, 1977
- [2] BATHE, K.I., WILSON, L.E: **E.F. A STRUCTURAL ANALYSIS PROGRAM FOR STATIC AND DYNAMIC RESPONSE OF LINEAR SYSTEMS**, University of California, Berkeley, 1973
- [3] BOANCĂ, C., MIRON L., PETHÖ, L., HĂRDĂU, M., TRIPA M.: **REZISTENȚA MATERIALELOR. METODE NUMERICE ȘI CALCULUL ÎN DOMENIUL PLASTIC**, Atelier de multiplicare Institutul Politehnic Cluj-Napoca, 1992
- [4] BRYDSON, J.A.: **PLASTICS MATERIALS**, Butterworth – Heinemann, Oxford, 1999
- [5] JOHN, V. B.: **INTRODUCTION TO ENGINEERING MATERIALS**, MacMillan Publishing Company, New-York, 1997
- [6] VASILACHE, V.: **TORPILĂ PENTRU DOZAT – INJECTAT**, Patent RO-99019, București, 1989