

PERFORMANCE ANALYSES OF KANBAN CONTROLLED PRODUCTION SYSTEM USING SIMULATION

ROTARU Ana

University of Pitesti, Faculty of Mechanics and Technology, Department of Management and Technology

e-mail: ana_c_rotaru@yahoo.com

Keywords: Kanban, controlled, system, performance

Abstract: Kanban control system is probably the most famous pull-type mechanism for multi-stage production system during the last few decades. This control discipline limits the amount of inventory to a fixed maximum for each stage consisting of a process and its output buffer, where the maximum is equal to the number of kanban circulating within the system. In the framework of this paper are presented and analyzed the performance of Kanban controlled system using simulation

1. INTRODUCTION

According to Kimura and Terada [2], production system can be classified into two types: push systems and pull systems. Most of the American and European production systems employ push systems whereas the Japanese JIT systems employ pull systems.

A push system allows production of produce the product in advance according to a predetermined plan. Materials arrive in the line according to a predetermined schedule, called materials requirements plan (MRP). In this case, the mechanism always maximizes inventory.

As pointed out in Baykoc and Erol [1] the main difference between the two systems is that in the pull system, the material is routed from the preceding stage to the succeeding stage according to the consumption rate of succeeding stage.

The point is that adopting a pull system in itself will not solve all production and quality issues. We cannot hope for thorough and new results without conceptual improvements. Unless we improve production systems so as to cut inventories drastically, we cannot approach a non-inventory ideal [6]. Monden [4] notes that the Kanban system is supported by the following conceptual improvements:

- Smoothing of production
- Standardization of jobs
- Reduction of setup time
- Improvement Activities
- Design of machine layout

The simulation, modeling and analysis of manufacturing systems for performance improvement have become increasingly important during the last few decades. Modern computer aided simulation and modeling tools help to visualize, analyze and optimize complex production processes using computer animations within a reasonable amount of time and investment.

Simulation modeling is the principal means of exploring production control used in this research. Numerous sources describe the use of simulation for predicting performance, comparing alternatives, and optimizing system designs. Law and Kelton [3] a well-known text on discrete-event simulation, discusses the simulation of manufacturing systems. In many cases, simulation studies have been used to gain insight into the behavior of manufacturing systems under different types of control policies (e.g., different dispatching rules) or to determine the accuracy of analytical models. Vollmann, Berry, and Whybark [7] review a number of results, for instance.

Thus, discrete-event simulation is an important tool for evaluating different production control policies. Moreover, finding a production control policy that achieves the best tradeoff between customer service, work-in-process inventory, cost and other performance measures is a difficult task.

Next we will present and analyse the performances of a production system controlled with the help of the Kanban method through total cost.

2. KANBAN SYSTEM

The kanban, which is Japanese for card, controls the production quantities in every process from the supplier to the customer. According to Monden , [4], in a kanban system, the type and quantity of units needed are displayed on a card which is sent between processes. This card indicates which parts an upstream process needs to produce for one of its downstream processes. The functions of a kanban, as described by Ohno, [5], are as follows:

1. Provides pick-up or transport information;
2. Provides production information;
3. Prevents overproduction and excessive transport;
4. Serves as a work order attached to goods;
5. Prevents defective products by identifying the process making the defects;
and
6. Reveals existing problems and maintains inventory control.

To implement the pull system idea in logistics systems efficient control mechanisms are necessary. In that context Kanban is one of the broadest investigated control mechanisms. The total cost is defined by a great number of variables (values), among which certain connections are established. The relation of dependence between these process values is defined function of the system and has the following form:

$$Y = F(X_1, X_2, \dots, X_k) \quad (1)$$

where X_j , $j = 1, 2, \dots, k$, represent the values independent of the system (the input values of the process taken into consideration), these values can be the stock cost, the clients demand, the period of equipment breakdowns etc. Y represents the dependent variable (the resultant value of the system taken into consideration, the total cost), while F is the form of the dependence relation (exponential, polynomial etc), which in connection with the name of the dependent variable is called the function of the dependent variable.

These functions "F" can be established theoretically or experimentally. The theoretical ones are introduced by definition or deduced due to economical reasons and they may lead most of the time to results which are very different from the experimental ones. The experimental functions are determined based on experimental results and can have various forms, generally using polynomial or polytropical regression functions.

3. FORMULTE MODELS

The models of the system were built according to the descriptions previously given. Figures 1 describe the graphical model of Kanban.

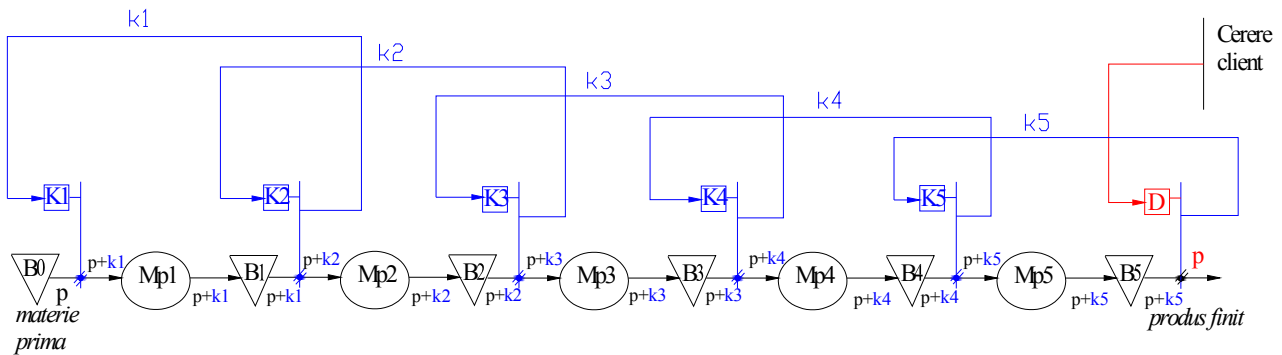

Fig.1. Kanban system

A few assumptions were made to simplify the simulation process. The most important assumptions were the following:

- The five stages are in series, each stage has only one supplier and one customer
- There is an infinite supply of raw parts at the input of the production input.
- Information is transmitted instantly
- Transportation within and between workstations is instantaneous
- The system produces a single part
- Kanban are associating with the part
- Any kanban detached at the output of a stage is immediately available for the upstream stage, there is not return delay
- There is no setup time in each machine
- Part authorized for loading follow a first come first serve (FIFO) dispatching policy at all machines.

4. EXPERIMENT

Following the experimental researches regarding the dependence of the total cost on the demand, machining failure and holding cost and dependences of this, we have established that the main total cost by lathing can be expressed by a relation, such as:

$$Y = A_0 + A_1 \cdot D + A_2 \cdot H + A_3 \cdot Mf + A_4 \cdot D \cdot H + A_5 \cdot D \cdot Mf + A_6 \cdot H \cdot Mf + A_7 \cdot D \cdot H \cdot Mf \quad (2)$$

then Y depends linearly on the X_1, X_2, X_3 variables.

This equation represents the mathematical model chosen to characterize the process or the phenomenon.

Starting from the data presented in table 1, meaning the admission parameters of the process, we have established an experimental factorial and fractional plan of the type 2^3 . This plan is presented in table 2.

Table 1. The values of the admission parameters of the process

The parameter	The real value	The normal value
Demand [EA]	D_{min}	90
	D_{med}	145
	D_{max}	200
Holding cost, [\$/ea]	H_{min}	3.5
	H_{med}	2.35
	H_{max}	1.2
Machining failure [h]	Mf_{min}	1.2
	Mf_{med}	3
	Mf_{max}	4.8

Table 2. The experimental plan

Exp	Real value							Normal value						
	D	H	Mf	DH	DMf	HMf	DHMf	D	H	Mf	DH	DMf	HMf	DHMf
1	90	1.2	1.2	108	108	1.44	129.60	-1	-1	-1	1	1	1	-1
2	200	1.2	1.2	240	240	1.44	288.00	1	-1	-1	-1	-1	1	1
3	90	3.5	1.2	315	108	4.2	378.00	-1	1	-1	-1	1	-1	1
4	200	3.5	1.2	700	240	4.2	840.00	1	1	-1	1	-1	-1	-1
5	90	1.2	4.8	108	432	5.76	518.40	-1	-1	1	1	-1	-1	1
6	200	1.2	4.8	240	960	5.76	1152.00	1	-1	1	-1	1	-1	-1
7	90	3.5	4.8	315	432	16.8	1512.00	-1	1	1	-1	-1	1	-1
8	200	3.5	4.8	700	960	16.8	3360.00	1	1	1	1	1	1	1
9	145	2.35	3	340.75	435	7.05	1022.25	0	0	0	0	0	0	0
10	145	2.35	3	340.75	435	7.05	1022.25	0	0	0	0	0	0	0
11	145	2.35	3	340.75	435	7.05	1022.25	0	0	0	0	0	0	0
12	145	2.35	3	340.75	435	7.05	1022.25	0	0	0	0	0	0	0

The total cost is directly determined by simulations. After simulation the experimental data, table 3, obtained on the basis of the research plan presented in table 2, an empiric relation was obtained in what concerns the influence of the demand, holding cost and machining failure on the main cost total.

Table 3. The values of the independent variables and those obtained for the dependent variable

Exp	Real value								CT
	D	H	Mf	DH	DMf	HMf	DHMf		
1	90	1.2	1.2	108	108	1.44	129.60	45009.4	
2	200	1.2	1.2	240	240	1.44	288.00	46234.7	
3	90	3.5	1.2	315	108	4.2	378.00	60605.1	
4	200	3.5	1.2	700	240	4.2	840.00	64174.3	
5	90	1.2	4.8	108	432	5.76	518.40	39565.5	
6	200	1.2	4.8	240	960	5.76	1152.00	43884.8	
7	90	3.5	4.8	315	432	16.8	1512.00	52256.7	
8	200	3.5	4.8	700	960	16.8	3360.00	61381.7	
9	145	2.35	3	340.75	435	7.05	1022.25	51651.3	
10	145	2.35	3	340.75	435	7.05	1022.25	51675.6	
11	145	2.35	3	340.75	435	7.05	1022.25	51679	
12	145	2.35	3	340.75	435	7.05	1022.25	51676.4	

The relation obtained after working on the data in table 3 is:

$$CT = 38684.12 - 5.46 \cdot D + 6659.5 \cdot H - 1502.5 \cdot Mf + 6.02DH + 4.57DMf - 549.04HMf + 2.7DHMf \quad (3)$$

Based on the regression relation obtained we have drawn diagrams of the type $TC=F(D)$, $TC=F(H)$, $TC=F(Mf)$, these diagrams point out the influence that each input parameter has on the output parameter. These diagrams are presented in the following figures.

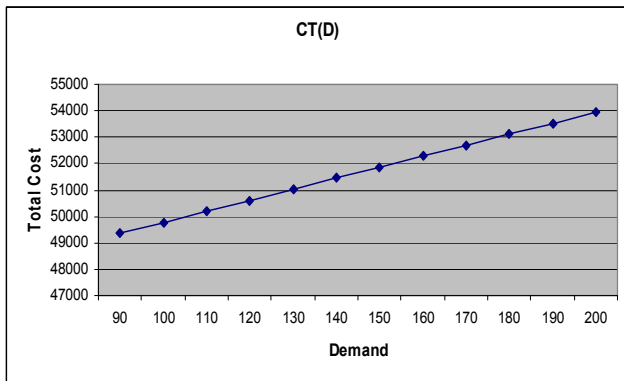

Fig. 2 The influence of the demand on the total cost

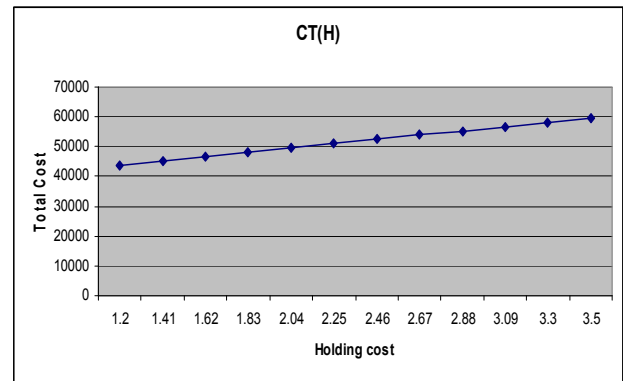

Fig. 3 The influence of the holdin cost on the total cost

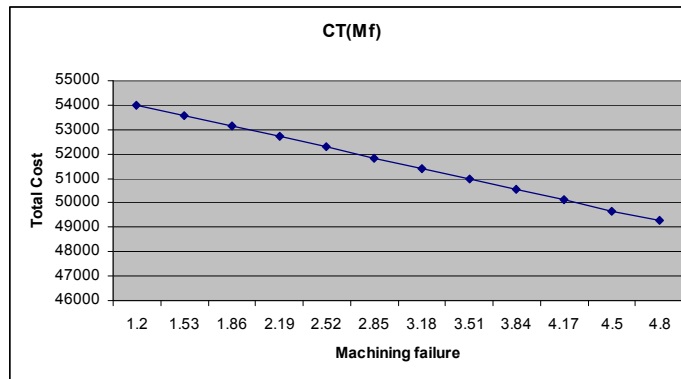

Fig. 4 The influence of the machining failure on the total cost

5. CONCLUSIONS

Following the experiments of the research plan and the analysis of the data obtained we draw the conclusions:

- by taking into account the slope of the dependence lines, $\alpha_{TC=F(C)} = 88^{\circ}27'$, $\alpha_{TC=F(HC)} = 89^{\circ}59'$ and $\alpha_{TC=F(Dmp)} = 89^{\circ}57'$, the order of the influence of the input parameter on the output parameter is: the stock cost, the average period of equipment breakdowns and the demand;
- the function of the total cost was determined after having chosen a model of the production system controlled with the help of the Kanban method and after following an experiment plan containing twelve tests;
- in the case of the twelve tests of the plan, the values of the total cost obtained after the simulation correspond to the values of the total cost within a production system controlled with the help of the Kanban method;
- the value of the total cost represents one of the assessing criteria of a production system's performances; this is why this study can be useful in choosing a production control method;
- the function of the total cost determined, valid for all the characteristics of the system taken into consideration, as well as the results obtained, represent a set of data meant to help one establish the values of some parameters of the system in order to achieve certain values of the total cost, thus, making possible the optimizing of the system.

REFERENCES

- [1] Baykoc O. F., S. Erol, 1998, *Simulation modeling and analysis of a JIT production system*, International Journal of Production Economics 55.
- [2] Kimura O. and H. Terada, 1981, *Design and Analysis of Pull System, a Method of Multi-Stage Production Control*, International Journal of Production Research 19
- [3] Law, A. M. and W. D., Kelton, 2000, *Simulation Modeling and Analysis, 3rd edition*, McGraw-Hill, New York.
- [4] Monden, Y., 1998, *Toyota Production System: An Integrated Approach to Just-In-Time*, Norcross, Georgia, Engineering & Management Press.
- [5] Ohno, T., 1998, *Toyota Production System*, Cambridge, Massachusetts, Productivity Press.
- [6] Robinson, A. 1990. *Modern Approaches to Manufacturing Improvement: The Shingo System*. Cambridge, M.A.: Shingo Shingo Productivity Press.
- [7] Vollmann, T. E., W. L., Berry, and D. C., Whybark, 1997, *Manufacturing Planning and Control Systems*, 4th ed. New York: Irwin/McGraw-Hill.