

COOLING TIME DETERMINATION ON PLANE INJECTED PRODUCTS FROM POLYSTYRENE

MIHĂILĂ Ștefan¹, GROZA Mihai¹, MADA Maria²

¹University of Oradea, ²Colegiul Tehnic "Ioan Ciordas" Beius
 mihailasna@yahoo.com, grozamd@uoradea.ro, maria.mada@personal.ro

Keywords: thermoplastic, mould, injection, cooling, thermal.

Abstract: The optimisation of the injection cycle in case of injection plastic materials suppose determination as correctly as possible of the cooling time in mould. Within the work theoretically investigates the relation of the cooling time in the case of shape plane injected article; the theoretical relations for determining the cooling time of some article from polystyrene generally use (PS) with different geometrical shapes are obtained as well as a nomogramme for determining the cooling time for a plane injected article.

1. INTRODUCTION

The productivity of injection machine depends on the time of injection cycle. Generally simplifying the injection cycle, the total injection time is:

$$t_t = t_u + t_r + t_m \quad (1)$$

where: t_u – fulling time of the mould

t_r – cooling time

t_m – dead time (pause and times of closing and opening the mould). [6]

By introducing some simplifying hypothesis, it here are determined some theoretical relations in order to determine the cooling time. Based on this, it is offered the possibility of practical determination of the cooling time in case of injection pieces.

2. THE DETERMINATION OF COOLING TIME EQUATION.

Analysing the relation (1), it is observed that the time of injection (t_t) depends direction on the cooling time (t_r). Theoretically determining t_r it is taking into account the plastic material, which flows in the mould cavity (fig. 1).

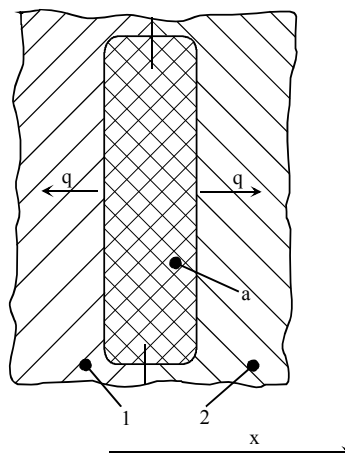

**Fig.1. The thermal transfer in case of the injection pieces in mould:
 1,2-forming plates; a- injected pieces; q-thermal high tide unitary on x direction. [7]**

They are introduced the following simplifying hypothesis:

- Plastic material is considered like a plane plate having the constant cooled on the both faces.
- They are neglected the marginal effects;
- It is neglected the anizotropia properties due to the macromolecules orientation;

- It is neglected the coefficient dependence of the thermal diffusing of temperature;
- The warming transfer is exclusively considered conductive.

Generally equation of the coordinating conducte is [7, 10]:

$$\frac{\delta T}{\delta t} = \frac{\lambda}{c_p \rho} \left(\frac{\delta^2 T}{\delta x^2} + \frac{\delta^2 T}{\delta y^2} + \frac{\delta^2 T}{\delta z^2} \right) \pm \frac{q_v}{c_p} \quad (2)$$

where:

- λ – coefficient of thermal conductivity, W/mK;
- c_p – specific warming to the specific presure , J/kg · K
- ρ – density Kg/m³
- q_v – the warming quantity of the volume unity, W/m³
- T – temperature, K
- t – time, s.

It is noted:

$$\frac{\lambda}{c_p \rho} = a \left[\frac{m^2}{s} \right], \text{ which is called thermal difuzivity.}$$

Analysing the thermal conductive transfer ,in case of material plastic plate, between the cooling walls of the moulds (fig.1), general shape of the equation (2) simplifies , considering that:

- The transitory transfer (interval time d_t the izoterm position is modified temporaly and in space:

There is no inside sources of heating, $q_v = 0$;

- The heating trasfer is done perpendicular on the plate surfaces (unidirectional transfer in x axes). So:

$$q_y = 0, q_z = 0$$

where: q_y – thermal high tide unit on y direction;

q_z – thermal high tide unit on z direction;

Due to the fact that the thermal fluxes on direction y and z are null, it results:

$$\frac{\delta^2 T}{\delta x^2} = \frac{\delta^2 T}{\delta y^2} = 0$$

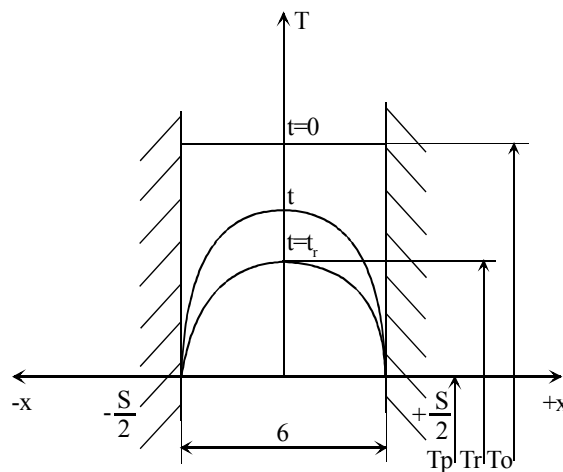

Fig.2.Cooling material plastic in the moulds: [7]

G-weight injected pieces; T_0 -temperature of plastical material $t=0$; T_p - the temprature of the mould walls ; T_r - cooling temperature.

It is considered material plate with median plan according to the $x = 0$ coordinate (fig.2). Noting the weight of the plate with G , Median plan corresponds $x = 0$ coordinate, and the laterally surfaces of the abscises: $x = \pm \frac{G}{2}$

It is considered that the material homogeneity plastic plate with initial temperature T_0 , it is sudden introduced, in the moment $t = 0$, in a cooling medium colling of temperature T_p (the temperature of moulding walls).

For $T = T_p$ și $x = \pm \frac{G}{2}$ becomes:

$$x = \frac{G}{2} \cdot T_p = A + B \cdot \frac{G}{2} + Ce^{-am^2t} \cos\left(m \frac{G}{2}\right) \quad (3)$$

$$x = -\frac{G}{2} \cdot T_p = A - B \cdot \frac{G}{2} + Ce^{-am^2t} \cos\left(m \frac{G}{2}\right) \quad (4)$$

Because the exterior faces temperature T_p at $x = \pm \frac{G}{2}$ is constant in time, resulted that the equations (3) and (4) does not to depend on time and, it has to fulfill the condition:

$$\cos\left(\pm m \frac{G}{2}\right) = 0 \quad (5)$$

With reation (7), the equations (3) and (4) become:

$$T_p = A + B \cdot \frac{G}{2} \quad A = T_p \quad (6)$$

$$T_p = A - B \cdot \frac{G}{2} \quad B = 0 \quad (7)$$

Putting the condition (5) it is obtained:

$$m \frac{G}{2} = \frac{(2n-1)\pi}{2}$$

By introducing in equation (3) the alues for A , B și m , rezulted the temperature at x distance from the center of the pieces:

$$T = T_p + C_e \frac{(2n-1)^2 \pi^2 at}{G^2} \cos \frac{(2n-1)\pi x}{G} [^{\circ}C] \quad (8)$$

The equations solution (8) are obtained for $1 \leq n \leq \infty$. La $t = 0$, the equation (11) becomes:

$$T = T_p + C \cos \frac{(2n-1)\pi x}{G} \quad (9)$$

Developing the temperature expression (8) it is obtained:

$$T = T_p + \sum_{n=1}^{\infty} \frac{4}{(2n-1)\pi} (T_0 - T_p) e^{-\frac{(2n-1)^2 \pi^2 at}{G^2}} \cdot \cos \frac{(2n-1)\pi x}{G}$$

Cooling time ($t = t_r$) its found in the equation (11), putting the condition that the plate temperature of plastical material at $x = 0$ to be $T = t_r$ (maximum temperature from the injected pieces):

$$t_r = \frac{G^2}{\pi^2 a} \ln \left(\frac{(T_0 - T_p) \cdot 4}{(T_r - T_p) \cdot \pi} \right) \quad (10)$$

For various types of injection shapes in the field $4 \leq \frac{(T_0 - T_p)}{(T_r - T_p)} \leq 100$, the values of cooling time

t_r could be followed in in the table 1[9].

Thermal difusion [cm²/s] $\frac{T_0 - T_p}{T_r - T_p} [^{\circ}C]$ time (s) Weight of walls (mm)

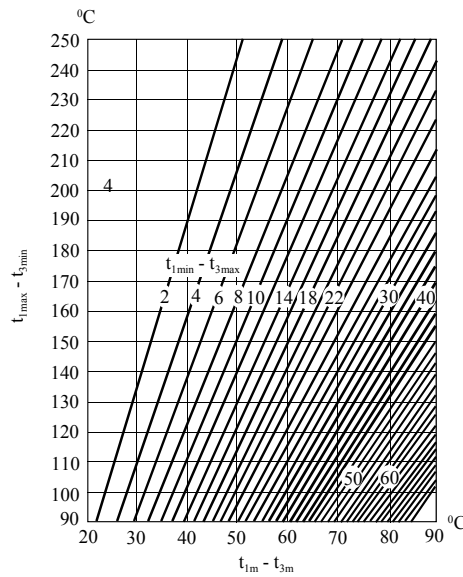

Fig.3. Nomograma for determining the cooling time in case of injected piece plate. [7]

3. PRACTICAL DETERMINATION OF THE COOLING TIME

Cooling time for injected piece having plate shape is determined by using nonograma shown in fig.3.

The diffusivity values of the thermal coefficient for various thermoplastic materials are found in the tabel 1[6].

Tabel 3. Represents data about the injection tehnology for several termoplastic material.

4. CASE STUDY

In following steps it is determined the cooling time of an injection pieces from polystiren, having plate shape with weight of 3 mm (fig.4)

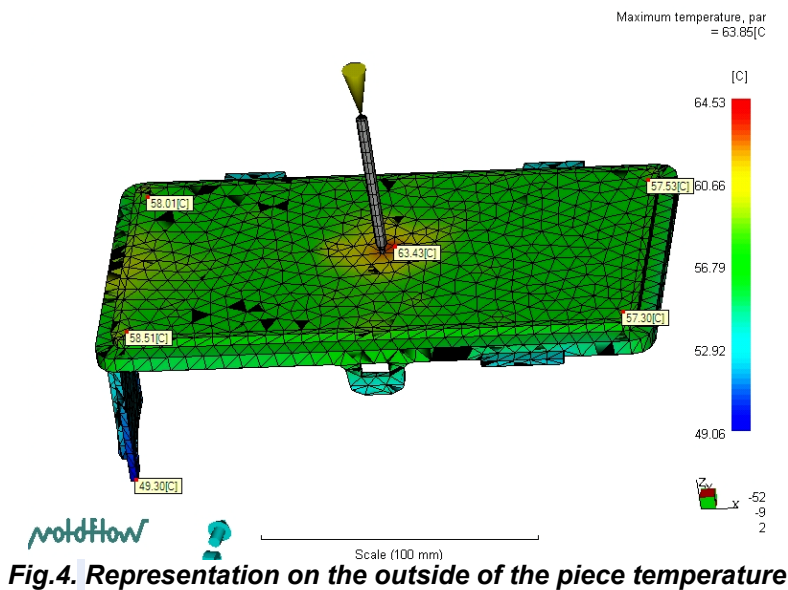

Fig.4. Representation on the outside of the piece temperature

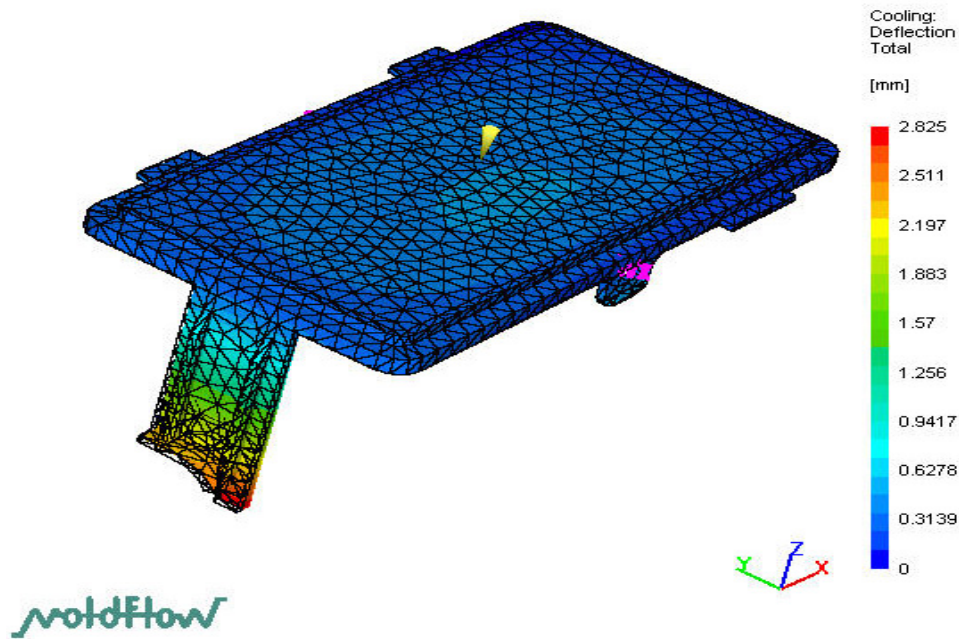

Fig.5. Represent deformations after cooling piece [7]

In table 1, it can analyse, the thermal diffusivity coefficient for polystiren which is $8,3 \cdot 10^{-4} \text{ cm}^2/\text{s}$.

The processing of polystiren injection offers the following data:

- Injection temperature $T_0 = 230^\circ\text{C}$ (table 3);
- The moulding walls temperature $T_p = 30^\circ\text{C}$ (table 3);
- The temperature from the moulding (maximum temperature in the middle of the pieces)
 $t_r = 70^\circ\text{C}$.

The report will be calculated:

$$\frac{T_0 - T_p}{T_r - T_p} = \frac{230 - 30}{70 - 30} = 5$$

from nomograma is obtained:

$$t_r = 6,5 \text{ s}$$

Table 1. The diffusivity termic coefficient for variase materials [6]

Thermoplastic material	The coefficientul of thermal difusivity, cm^2/s
HDPE	$7,7 \cdot 10^{-4}$
LDPE	$7,4 \cdot 10^{-4}$
PP	$7,6 \cdot 10^{-4}$
PS	$8,3 \cdot 10^{-4}$
PVC	$4,8 \cdot 10^{-4}$

Table 2. Cooling time for various geometrical injected shapes: [5]

Shape	Dimensions	Cooling time t_r	t_{tr}/t_r plate	Relative error [%] pt $(T_0-T_M)/(T_P-T_M)$		Relative error=0 $(T_0-T_M)/(T_P-T_M)$
				4	100	
Plate	Weight	$\frac{s^2}{\pi^2 \cdot a} \ln\left(\frac{4 T_0 - T_p}{\pi T_r - T_p}\right)$	1	-	-	-
Cylinder	Diametre Length	$\frac{d^2}{23,14 \cdot a} \ln\left(1,599 \frac{T_0 - T_p}{T_r - T_p}\right)$	$0,465 \cdot \left(\frac{d^2}{g}\right)^2$	+3,7	-4,6	10
Cone	Diametre	$\frac{d^2}{4\pi^2 \cdot a} \ln\left(2 \frac{T_0 - T_p}{T_r - T_p}\right)$	$0,250 \cdot \left(\frac{d^2}{g}\right)^2$	+7,6	-8,4	9
Parallelepiped	Width Length Height	$\frac{1}{\left(\frac{1}{l^2} + \frac{1}{h^2}\right)\pi^2 \cdot a} \ln\left(\frac{16 T_0 - T_M}{\pi^2 T_P - T_M}\right)$	$\frac{1,10}{1 + \left(\frac{1}{s}\right)^2}$	+4,6	-4,6	10

Tabelul 3. Injection temperature and moulding temperature for different thermoplastic material

Thermoplastic material	Injection temperature °C	Moulding temperature °C
LDPE	170 - 260	0 - 70
PS	200 - 250	30 - 6
PA6.6	260 - 300	40 - 120
PC	280 - 310	85 - 120
PP	180 - 280	0 - 80
ABS	180 - 220	40 - 80
PVC	160 - 190	20 - 80

4. CONCLUSION

The theoretical determination of the relations expressing cooling time in the mould of an injected piece from thermoplastic material, permits the construction of the monograms. The use of monograms offers the possibility of determining the optimal cooling time, contributing to a real appreciation of the injection cycle made by injection machines. This method contributes significantly to reducing strains when injected plastic parts flat shape helping to increase productivity.

REFERENCES:

- [1] Fetecău, C. (2005), *Injection plastics material*. Publisher Didactic and Pedagogic Publishing Bucharest,
- [2] Friedl, C. (1996), *Progress Toward True 3D CAE Analysis for Injection Molding*, Moldflow International Pty. Ltd., Antec.
- [3] Kennedy, P., YU, H. (1994) - *Plastic CAE Analysis of Solid Geometry*, Moldflow International Pty Ltd. Antec.
- [4] Hahnemann, S. (1996), „*Verarbeitung von Plaste*” VEB Deutscher Verlag für Grundstoffindustrie Leipzig
- [5] Menges, G. și Mohren, P. (1997) - „*Anleitung für den Bau von Spritzgießwerkzeugen*” Carl Hanser Verlag München.
- [6] Menges, G. Schmit, L., Kemper, V., Storzer, A. (1980), *Plaste-Verarbeiter nr. 4*, pp. 197-202.
- [7] Mihăilă, Șt. (2004), *Determination of cooling time in the mould at the processing by injection of thermoplastic materials*. International Conference TOOLS, 22-23 april, Bratislava, ISBN 80-227-2043-7 pp.76-80.

- [8] Mihaila, St., Fazecas, M., Chira, D., Pop, A., Porumb, C., (2009), *Experimental researches regarding the influence of the injection moulding temperatures on quality plastical with complex shape*. The 20th International Daaam Symposium "Intelligent Manufacturing & Automation: Theory, Practice & Education" 25-28th November Vienna, Austria. ISSN 1726-9679, pp 1083-1085.
- [9] Ștefănescu, D., Marinescu. (1983), *Termotechnics* Teaching and Teacher Publisher Bucharest.
- [10] ****Moldflow 2.0*, (1995), Technical documentation.
- [11] ****Fullanalyse ohne Netzgenerung*. (1997), Kunststoffe, Nr. 9.