

ADVANCED TECHNOLOGICAL METHODS OF PROCESSING SHOE LASTS IN FOOTWEAR INDUSTRY

ALBU Adina¹, GANEA Macedon¹, ANDRIȚOIU Octavian², INDRIE Liliana¹, PRICHICI Mariana¹, ROMOCEA Sanda¹

University of Oradea, adina_victoria@yahoo.com, DMG Romania Sales & Services

Keywords: milling, virtual 3D, last, modeling, turning

Abstract: This work of paper is about how to obtain the lasts. There are two proceders to realize the surface of a solid, in our case, the surface of the last. It is possible to mill a block of plastic or to turn in a turning machine, both of them having CNC program.

1.INTRODUCTION

1.1. TURNING

Can be achieved by processing center CTX-300 by turning the block around the axis of rotation C and turning heads with Live Tooling cutter head, provided with spherical finger milling or Thor milling.

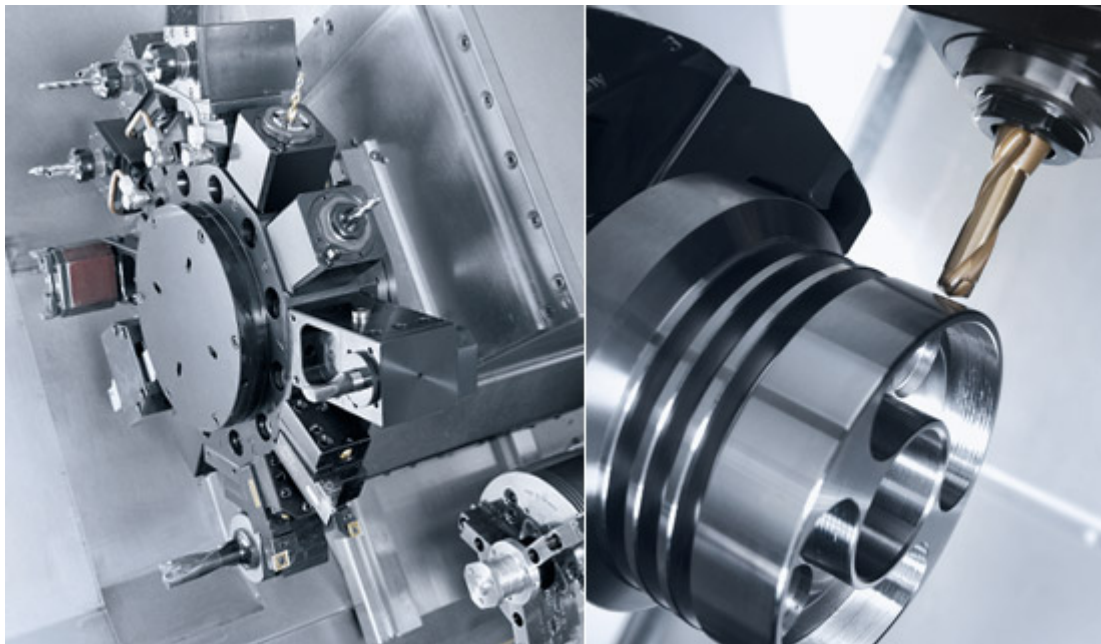

Figure 1- Live Tooling Milling head with different cutters and workpiece clamping jaw lathe

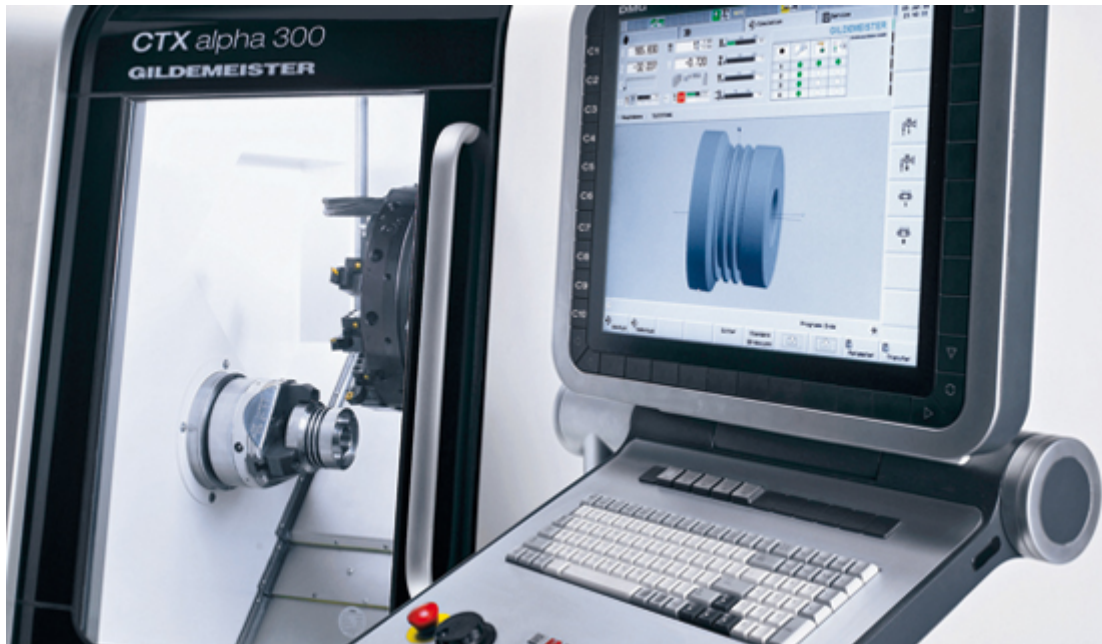

Figure 2 -Control equipment and machine control CTX alpha 300

1.2. DESCRIPTION OF VERTICAL MILLING.

Series machines DMU-50 ECO, CNC 5-axis technology provides the most advanced and most accurate available in the market. Optimized design of the machine can overcome challenges and plays a brand, especially if an expert system control input for configuring the machine.

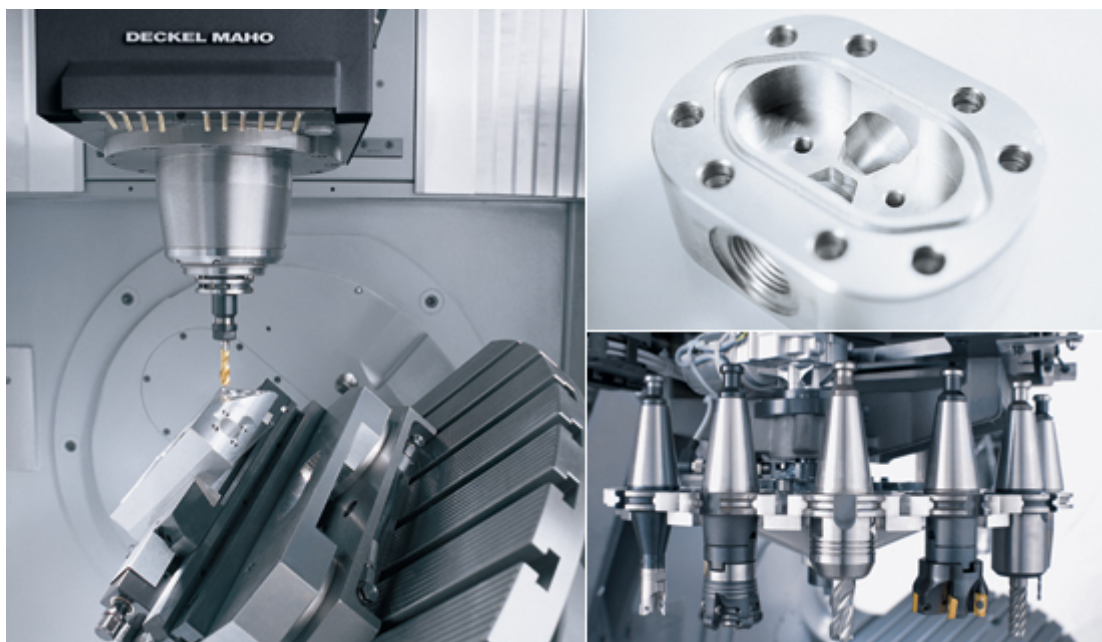

Figure 3 - Tilting rotary table and rotating the tool magazine

DMU 50 has a tilting rotary table more processing performance simultaneous 5 axes.

2. DESCRIPTION FIXATIONS BLOCK OF THE LAST ON TWO MACHINES

To get a quality footwear is necessary the last surface to be high quality. Shoe lasts can be manufactured wooden or plastic and are the result of creator of designs in wood carving or milling / turning a block of high density polyethylene with finger-type cutter or Thor-type cutter.

Current methods for obtaining of lasts are copying the model carved with specific machine or digitizing printed lasts and generation of the model in CNC. One of the most modern methods of production is as a method of generating a virtual block of the last. The study was done on universal CTX 310 eco-center and milling machine DMU-50 with tools like finger-type cutter with round head and Thor-type cutter.

Fixation 1: CTX -310-ECO-DECKEL-MAHO

Tool: Finger-type cutter with round-head

Universal chuck is mounted between the hook block to be horizontal, rotating around the axis C. The Live-Tooling tool located in radial position is set with round-headed finger-type cutter moving on axes x and z with axial advance and rotation n.

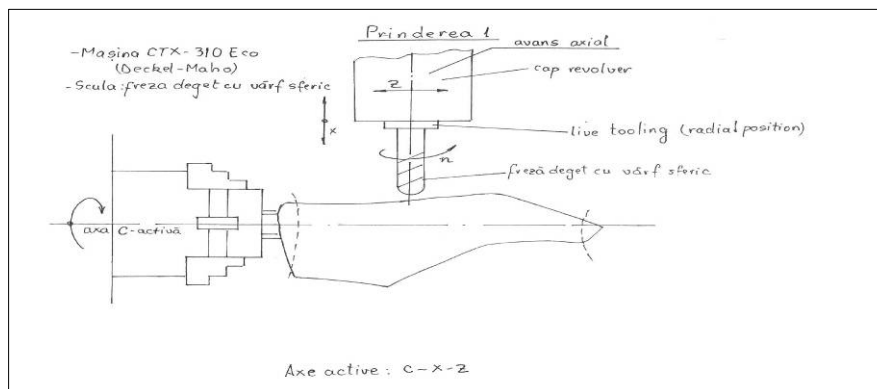

Figure 4 - Diagram representing milling machine on horizontal fixation last with finger-type cutter

Fixation 2: CTX- 310-ECO-DECKEL-MAHO

Tool: Finger-type cutter with round-head

Block of the last is in the vertical position and rotate on the axis C. Finger-type cutter with round-head moves on x and z axes and with advance axial and rotation n, is milling the block of last.

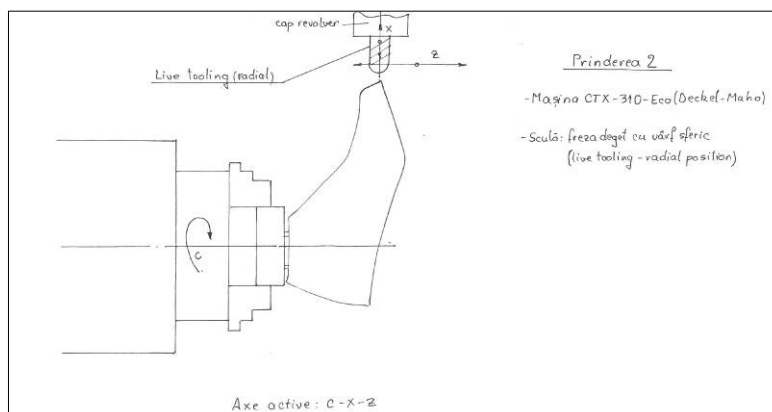

Figure 5 - Diagram representing milling machine on vertical fixation last with finger-type cutter

Fixation 1: CTX- 310-ECO-DECKEL-MAHO

Tool: THOR mill

CTX 310 ECO Universal-center is fitted with a Live-Tooling Thor mill located axial positioned horizontally. Movement is done on the device axes x and z. Block of the last is also horizontal, rotating around the axis C.

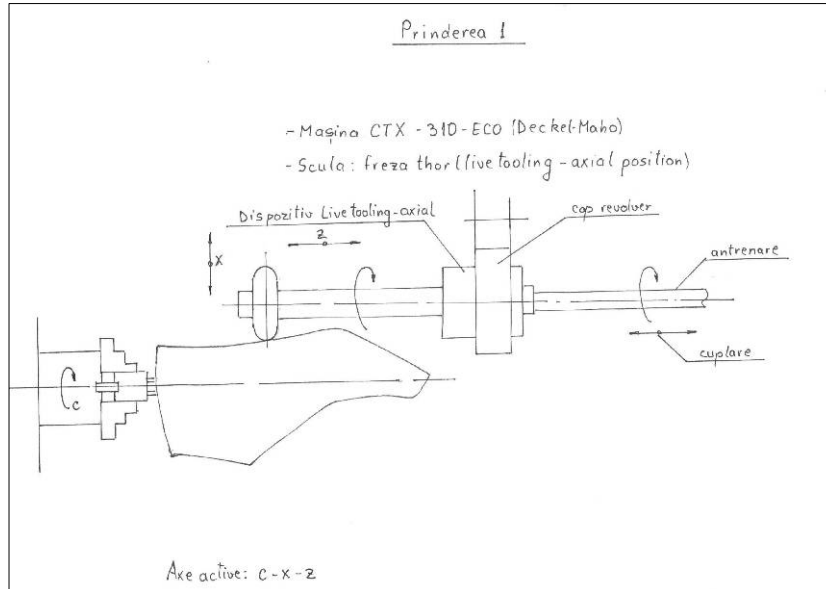

Figure 6 - Diagram representing milling machine with Live-Tooling device in horizontal fixation of the last

Fixation 2: CTX -310-ECO-DECKEL-MAHO

Tool: THOR mill

Block is positioned vertically mounted between the universal chuck and rotate around the axis C. Thor cutter is coupled thru the Live-Tooling axially moving horizontally on x and z axes.

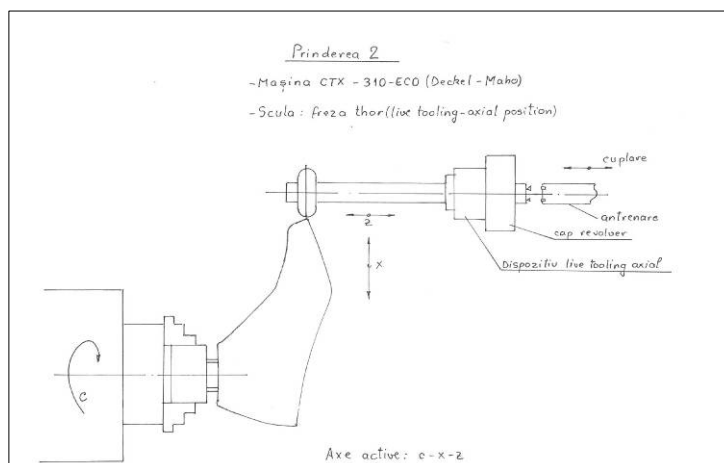

Figure 7 - Diagram representing milling machine with Live-Tooling device in vertical fixation of the last

Fixation 1:- DMU-50-DECKEL-MAHO

Tool: Finger-type cutter with round-head

This clamping block is placed horizontally on a table rotating inclined axis of rotation axis has been required milling block. Clamping device built specifically shaped "L", makes a sweep of the block so that milling has been done with as little vibration and a fidelity as possible.

Finger-type cutter with round-head has rotation and moves in x and z axes, the y-axis is locked. Tool running on the z axis and is inclined minimum milling CNC system has saved him and not below that angle.

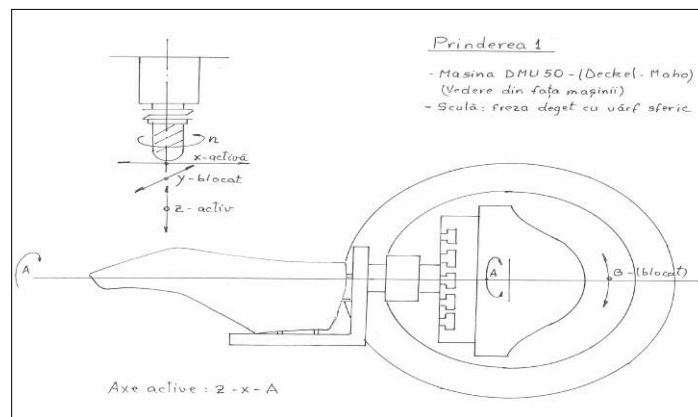

Figure 8 - Diagram representing milling machine DMU-50 on horizontal fixation last with finger-type cutter

Fixation 2 - DMU-50-DECKEL-MAHO

Tool: Finger-type cutter with round-head

If such undertakings, block is set upright on the tilting rotary table. Block rotates around axis A and milling finger approaches the z axis and moving the x-axis, yielding the milling block of the last. As in previous grip, finger milling under an angle of inclination is the minimum required speed milling and have the rotation n. Mounting block the rotating table is achieved with a flange that allows the rotation block, so that it can be milled in all necessary areas.

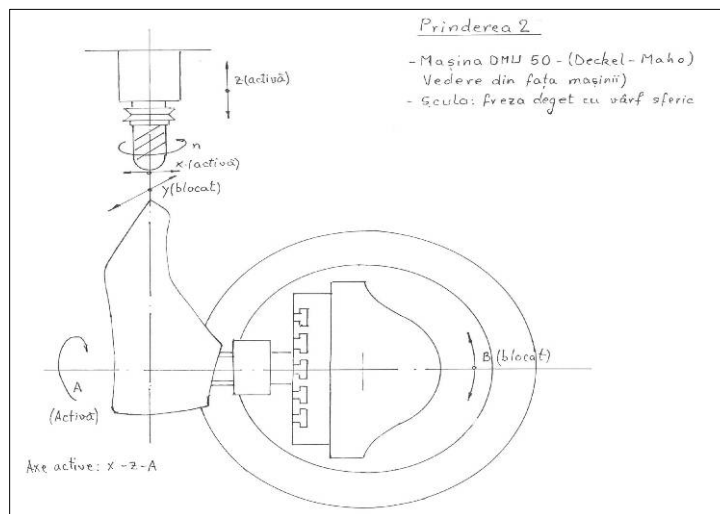

Figure 9 - Diagram representing milling machine DMU-50 on vertical fixation last with finger-type cutter

Fixation 1:-DMU-50-DECKEL-MAHO

Tool: THOR mill

Perform milling cutter block with Thor, moving the x and z axes and rotating block is fixed on the table tilted upright on a support in the form of "L". Block rotates around the axis C.

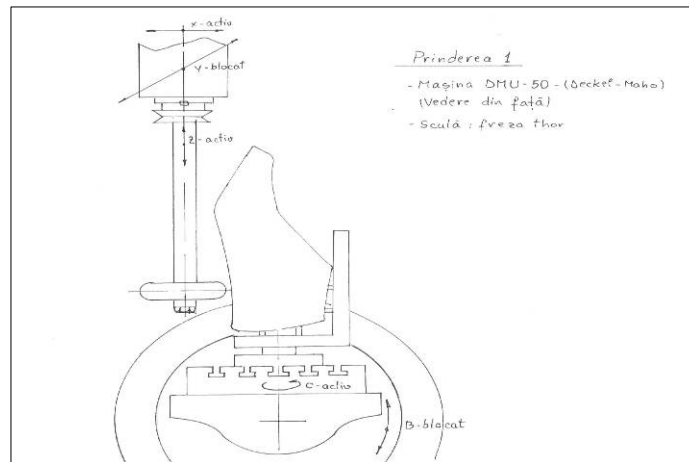

Figure 10 - Diagram representing milling machine DMU-50 with Live-Tooling device in vertical fixation of the last

Fixation 2:- DMU-50-DECKEL-MAHO

Tool: THOR mill

Horizontal block position is being fixed on the table tilting and rotating the rotating axis C.

Thor cutter moving x and z axis with speed n.

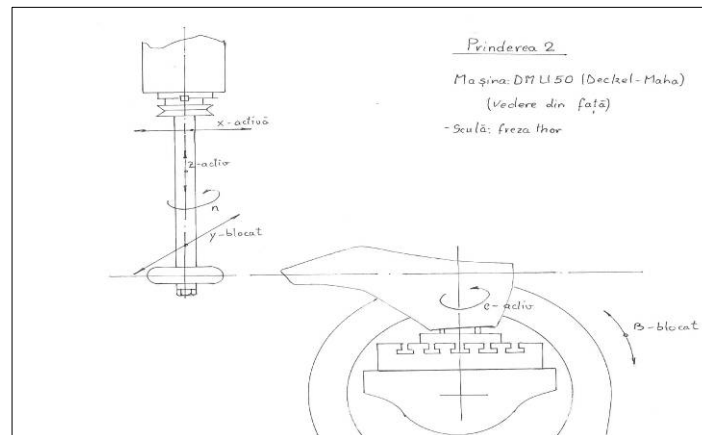

Figure 11 - Diagram representing milling machine DMU-50 with Live-Tooling device in horizontal fixation of the last

Next picture show how is positioned on DMU-50 the block of last and how will be positioned finger-type cutter to realize milling of the last. This picture was taken in the show-room from DMG Romania- Pitești where is milling the last, after a virtual model which is obtained by scan.



Figure 12 - Positioning of the last and finger-type cutter for processing

ACKNOWLEDGMENT

My Acknowledgments to the board of DMG Romania- Pitești for their professionalism and collaboration to due the study on the CNC milling machine.

3.CONCLUSIONS

3D last may be quickly designed automatically in under 2 minutes, for its mechanisation using the appropriate sources. It is a development that offers a complete solution in the foot health and safety field. To manufacture lasts, DMG Romania- Pitești has numerical control lathes that operate using the data provided by these same programmes.

The integration of the entire footwear personalisation process is performed using a web computing system, in such a way that greater functionality and efficiency is obtained, making the footwear selection process independent to the management and manufacturing process.

The main result is the obtaining of a clearly differentiable, innovative product that is totally adapted to the needs and preferences regarding fashion and safety established by the customer so that it can supply and respond to a segment of the market. Furthermore, the shoes are personalised, making them unique for each particular case and each customer.

[1] Albu A., Ganea M., Suteu M.- ABOUT THE VIRTUAL SOLID CORECTION IN THE CASE OF SHOE LAST BY USING OF THE ANTROPOMETRICAL PARAMETERS- Annals Of The Oradea University, "Fascicle Of Textile- Leatherwork", INTERNATIONAL SCIENTIFIC CONFERENCE-

"Innovative solutions for sustainable development of textiles industry", 29-30 May, Oradea, 2009

[2] Albu A., Ganea M., Suteu M.- CONSIDERATIONS ABOUT OF THE DIGITIZING METHOD TO THE VIRTUAL SOLID PERFORMING IN THE CASE OF SHOE LAST INDUSTRY- Annals Of The Oradea University, "Fascicle Of Textile- Leatherwork", INTERNATIONAL SCIENTIFIC CONFERENCE-

"Innovative solutions for sustainable development of textiles industry", 29-30 May, Oradea, 2009

[3] dmgromania.com