

STUDY ON DEGREE OF DEFORMATION AND FAULTS IN THE COURSE OF DIRECT EXTRUDING TECHNOLOGICAL OPERATION

STĂNCIOIU Alin, POPESCU Gheorghe
University "Constantin Brâncuși" of Targu-Jiu

Key words: extrusion, scale, sliding, pores, cracks

Abstract: Within the plastic deformation while extruding there is the possibility that the outward faults of the semiproduct be driven inside the part. Under extreme conditions the pores may be connected among them, forming inward cracks. The distortion of the material sliding scale depends upon r and α . It may be noticed that the distortion of the scale shall increase in direct ratio with the increase of Δ .

Thank to the unsatisfied conditions of extrusion, like the lack of lubricating, extrusion large angle, etc., the materials may show Chevron cracks.

1. Generalities

The cold extrusion is the operation dealing with the deformation of the massive semiproducts upon the basis of the plastic flow of the metal by the clearance between punch and working plate.

There are 3 extrusion methods:

a) The direct method, where the material flow occurs in the direction of the working movement of the punch fig. 1.a;

b) The reverse method, where the metal flow occurs in the opposite direction of the working movement of the punch fig. 1.b;

c) The compound method, meaning the combination of the first two methods fig. 1.c.

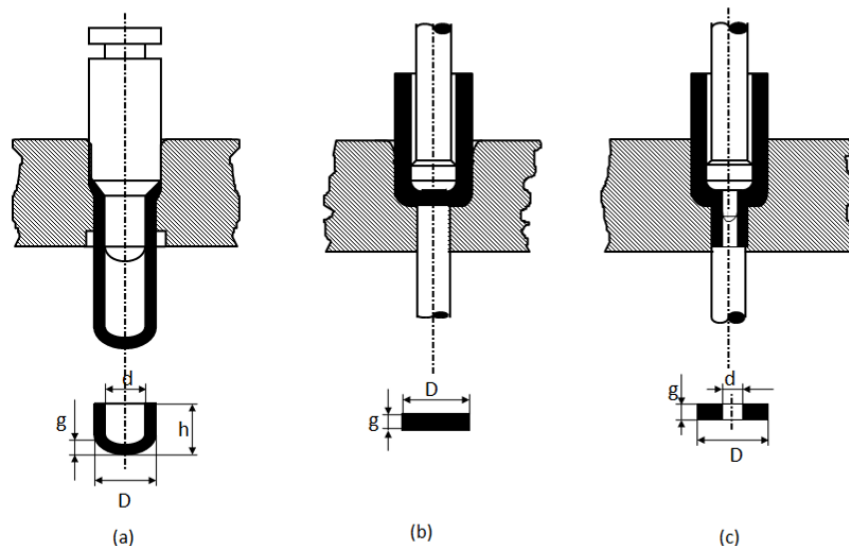

Fig.1 Methods of extrusion

The main factors making up an influence upon the material flow by the clearance among the working elements of the tool, respectively the quality of the parts to be got depends upon, too, are the following:

1. Extrusion method;
2. Plastic characteristics of the material subdued to deformation;
3. Geometry of working plate and punch;
4. Lubricating;
5. Deformation velocity.

2. Direct Extrusion.

While deforming the material in the course of the direct extrusion may be noticed 3 different stages:

1. Pressing the semiproduct in the container of the working plate until starting the metal flow through the extrusion hole fig. 2.a;
2. Flowing the metal from the container through the extrusion hole until $h_s > h_{sc}$ fig.2.b;
3. Flowing the metal from the container through the extrusion hole until $h_s < h_{sc}$ fig. 2.c.

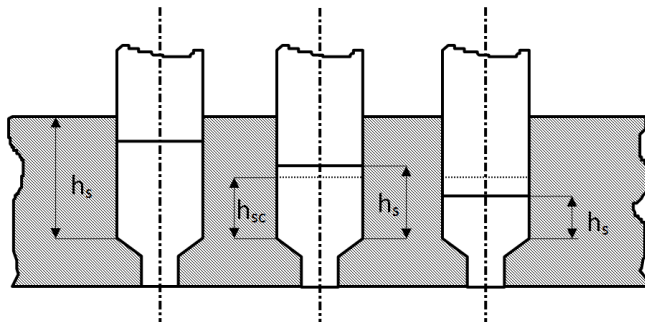

Fig.2 Extrusion stages

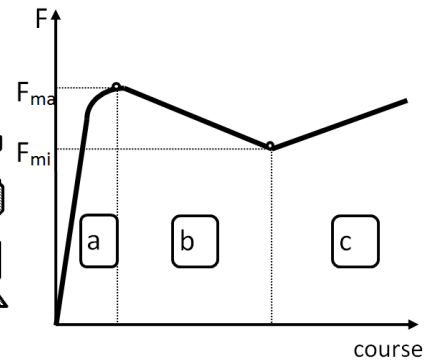

Fig.3 Variation of extruding force

The 3 stages stand out distinctly by the variation of the extrusion force fig.3.

Thank to the friction between the contact surfaces of the semiproduct and tool the deformation shall be patchy inside the semiproduct and certain areas shall be deformed only in an elastic manner fig.4. The areas 1 and 3 are deformed in an elastic manner, the area 2 shall be deformed in a plastic manner and under certain working conditions the area 2 may reach the central part of the semiproduct, with the danger of driving some oxids which are present on the outside surface.

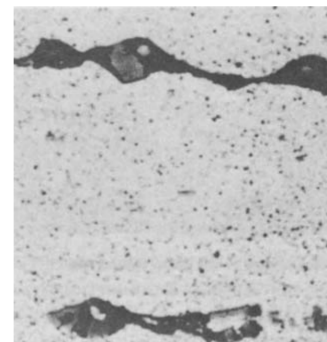
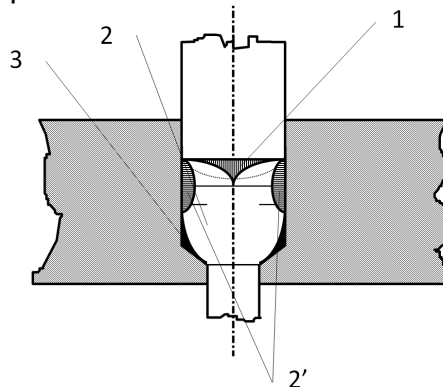

Fig4. Deformed areas during the extruding course Fig.5. Early stage of connection among pores.

Both the volume and configuration of areas deformed in an elastic manner depend upon the typical angle of working plate and lubricating conditions. The last period of deformation is very important since the crossing flow velocity of the material shall be increased and when it becomes turbulent there is the possibility that the outward faults of the semiproduct be driven inside the part. Under extreme conditions the pores may be connected among them, forming inward cracks fig.5.

3. Degree of Deformation

The shape of the deformation zone has a strong influence on the redundant work, the frictional work, and the forming forces. It also influences the properties of the product material. The homogeneity, the tendency to crack, the pattern of residual stresses, and the porosity are all affected by the deformation-zone geometry. The parameter, defined as the ratio of the thickness or diameter, H , to the contact length between work piece and die, L , has a large effect on these properties:

$$\Delta = H/L. \tag{1}$$

For plane-strain extrusion and drawing, the contact length:

$$L = (H_0 - H_1)/(2 \sin \alpha) \tag{2}$$

and the mean thickness:

$$H = (H_0 + H_1)/2, \tag{3}$$

So

$$\Delta = \frac{(H_0 + H_1)}{(H_0 - H_1)} \sin \alpha. \tag{4}$$

Substituting the reduction

$$r = (H_0 - H_1)/H_0, \tag{5}$$

$$\Delta = \frac{2 - r}{r} \sin \alpha. \tag{6}$$

Thank to the high plasticity of the material under work, while directly extruding, may be got degrees of deformation to 80% at a single operation.

Fig. 6 shows the distortion of the material sliding scale depends upon r and α . It may be noticed that the distortion of the scale shall increase in direct ratio with the increase of Δ .

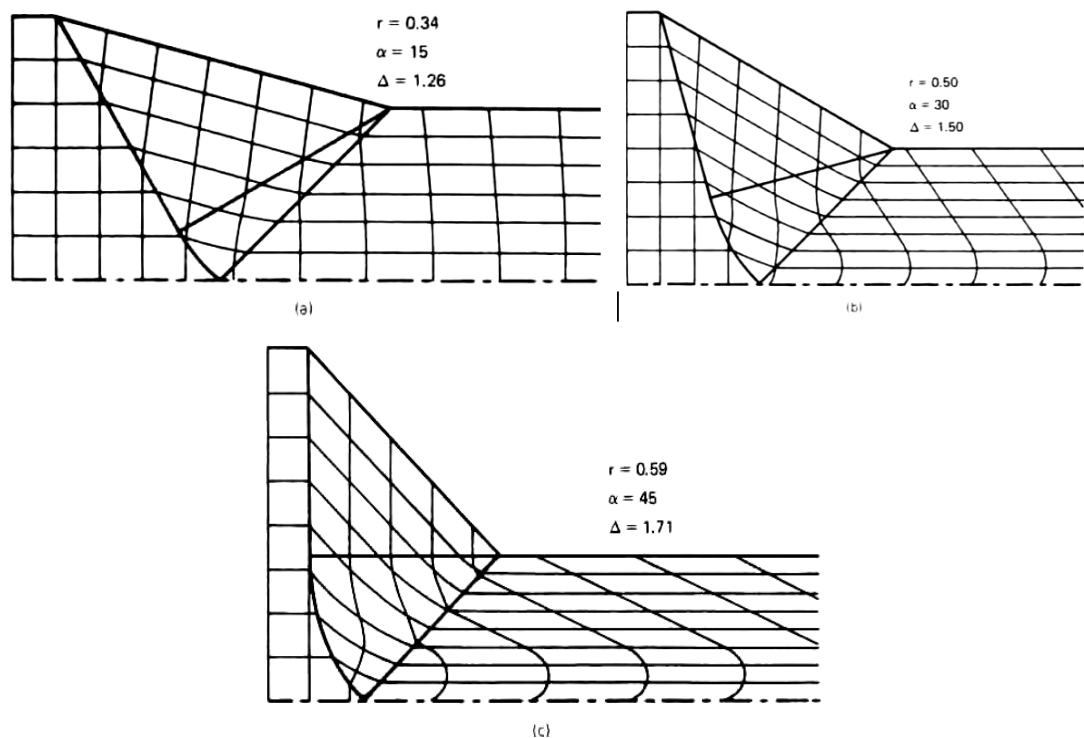

Fig. 6 Distortion of the material sliding scale depending upon r and α

4. Faults

Thank to the unsatisfied conditions of extrusion, like the lack of lubricating, extrusion large angle, etc., the materials may show Chevron cracks. The axle of the parts shall flare, the cracks showing an arrow head fig.7 and in the same time similar cracks are formed in the rolling rod fig. 8. Avitzur studied the problem of the axle blowing out and found out the condition central holes are formed : $\Delta > 2$.

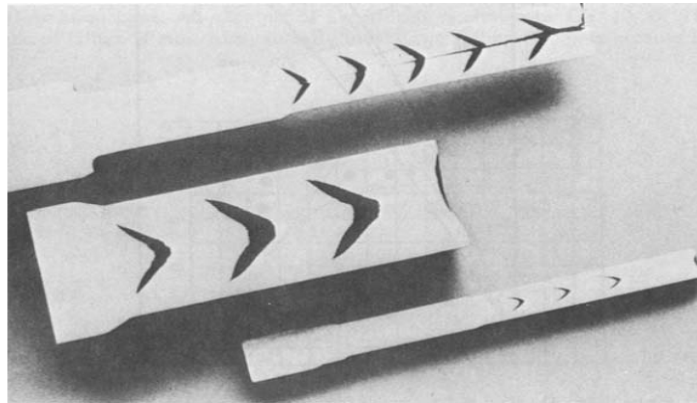

Fig.7 Chevron cracks formed during extrusion of steel rods



Fig.8 Cracks formed in a molybdenum bar during rolling under high conditions.

5. Conclusions

The last period of deformation is very important since the crossing flow velocity of the material shall be increased and when it becomes turbulent there is the possibility that the outward faults of the semiproduct be driven inside the part. Under extreme conditions the pores may be connected among them, forming inward cracks.

Thank to the high plasticity of the material under work, while directly extruding, may be got degrees of deformation to 80% at a single operation.

The distortion of the material sliding scale depends upon r and α . It may be noticed that the distortion of the scale shall increase in direct ratio with the increase of Δ .

Thank to the unsatisfied conditions of extrusion, like the lack of lubricating, extrusion large angle, etc., the materials may show Chevron cracks. The axle of the parts shall blow out, the cracks showing an arrow head fig.8 and in the same time similar cracks are formed in the rolling rod. The condition central holes are made up under is $\Delta > 2$.

Bibliography

- [1] William F. Hosford, Robert M. Caddell-Metal forming, Mechanics and Metallurgy, Third Edition, Cambridge, 2004
- [2] Şonţea, Sever, Metale și aliaje neferoase de turnătorie, Ed. Scr. Românesc Craiova, 1981
- [3] Stăncioiu Alin, Cercetări cu privire la influența calității sculelor asupra proceselor tehnologice de tăiere, Universitatea din Craiova, Teza de Doctorat, 2004