

## **TRANSVERSAL MOBILE COUPLING KINEMATICS, AS MULTIBODY SYSTEM**

**GAVRILĂ Cătălin Cornel**

Transilvania University of Braşov, Dept. of Product Design and Robotics

[cgavrila@unitbv.ro](mailto:cgavrila@unitbv.ro)

**Keywords:** Mobile coupling, multibody system, geometrical and kinematical constraints.

**Abstract:** Mechanical systems definition as multibody systems is a modern way of modeling aiming to the real time simulation of complex product's dynamic behavior, using computer performing programs. For a company, it saves time in product developing, reduces the number of physical prototypes and experiments, reduces the prices and also, increases the quality of product. The paper presents aspects regarding the kinematics of the transversal mobile coupling as three mobile bodies multibody system. Previously, based on an adequate graph and specific conditions, like the degree of freedom, number of bodies and the type of geometrical constraints between the bodies, the synthesis of all possible graphs for transversal couplings as multibody systems with 3, 4 and 5 mobile bodies were developed. First it is presented the structural scheme of the analyzed mobile coupling. Then are defined: the parts of the multibody system associated to the mobile coupling (input and output semicouplings, intermediary element and basis); the body reference frames and also the general reference frame; the geometrical and cinematic constraints. Finally, there are determined the cinematic equations, useful to found the optimal geometrical configuration of the coupling, depending by the initial requests of a mobile coupling (cinematic and constructive conditions) and also to obtain some new constructive variants, presented in the final part of the paper.

### **1. INTRODUCTION**

The mobile couplings are used in a lot of power transmissions at cars, road trucks, railway trucks, ships and other industrial systems, in movement and torque transmission between two shafts with parallel axis. The shafts are connected by a kinematical linkage with the possibility to have translations in the transversal plane. These translations are named transversal movements. A transversal coupling is homokinetic if the shafts angular speeds are identical. If the shafts angular speeds are almost identical, the mobile coupling is quasihomokinetic [1].

If the shafts are connected to the basis, it will result the associated mechanism, which is a plane mechanism [1]. The associated mechanism can be represented simplified, using some graphic modules, previously introduced [4]. The transversal coupling multibody model has, as bodies, the input and output shafts and also, some of the intermediary bodies which have, usually, more than two connections [2...6].

### **2. THEORETICAL BASIS**

The analysed transversal mobile coupling (Oerlikon type) is composed by two semicouplings and between them there are the intermediary elements (fig. 1) [1].

The bodies of the multibody system are: input semi-coupling, 1, intermediary body 2, output semi-coupling 3 and the basis 0. Between the bodies there are the restrictions detailed in table 1. Between the bodies there are the restrictions detailed in table 1 and figure 2. The mobility of the associated mechanism multibody system is [5]

$$M = 3(n_b - 1) - \sum g_c = 3(4 - 1) - 8 = 1, \quad (1)$$

where  $n_b=4$  is the number of the associated mechanism bodies (including the basis) and  $\sum g_c=8$  is the number of the geometrical constraints between the bodies.

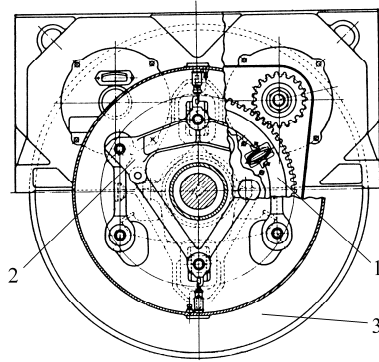

a. Coupling constructive scheme.

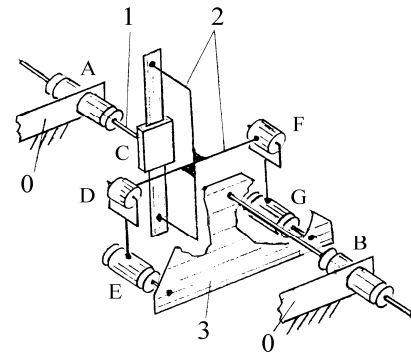

b. Structural scheme of the associated mechanism.

**Figure 1. The transversal mobile coupling, type Oerlikon**

Table 1: Restrictions

Body i – Body j	Geometrical constraint	Joint	Number of restrictions
0 – 1	R	A	2
0 – 3	R	B	2
1 – 2	T	C	2
2 – 3	RR+RR	DE , FG	1+1

For the mobile transversal coupling shown in figure 1, the geometrical and kinematical multibody model is presented in figure 2. The interest point's coordinates are presented in table 2.

To define the geometrical restrictions, is necessary to know the point coordinates relative to the fixed coordinates system. The general relation of these coordinates is [5]:

$$\begin{bmatrix} x_{M_i} \\ y_{M_i} \end{bmatrix} = \begin{bmatrix} x_{0i} \\ y_{0i} \end{bmatrix} + \begin{bmatrix} \cos \varphi_i & -\sin \varphi_i \\ \sin \varphi_i & \cos \varphi_i \end{bmatrix} \begin{bmatrix} r_{ix} \\ r_{iy} \end{bmatrix}, \quad (2)$$

where  $i=1, 2, 3$ , for mobile bodies.

Geometrical restrictions equations are obtained from the geometrical restrictions between the bodies and are presented as follow.

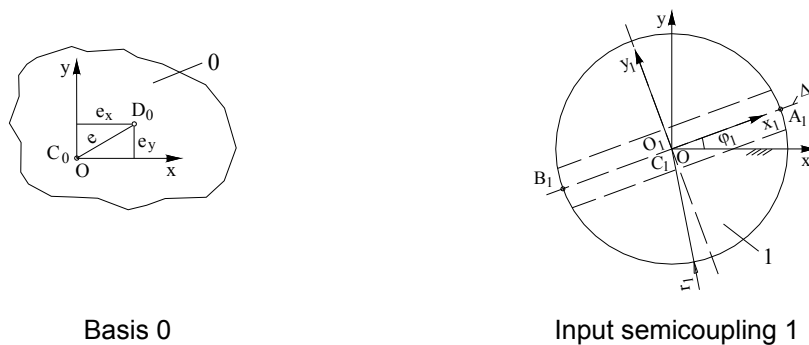

**Fig. 2. The geometrical and kinematical multibody model**

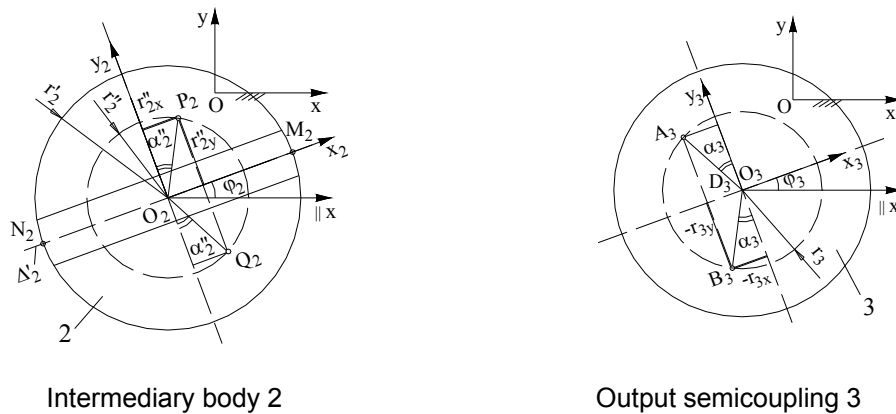

**Fig. 2. The geometrical and kinematical multibody model (continued)**

Table 2: Points coordinates relative to the local coordinate system.

Body	Points coordinates
Basis 0	$C_0(0, 0); D_0(e_x, e_y).$
Input semicoupling 1	$A_1(r_1, 0); B_1(-r_1, 0); C_1(0, 0)$
Intermediary body 2	$M_2(r'_2, 0); N_2(-r'_2, 0); P_2(r''_{2x}, r''_{2y}), Q_2(r''_{2x}, -r''_{2y}),$ where: $r''_{2x} = r'_2 \cos \alpha''_2$ and $r''_{2y} = r'_2 \sin \alpha''_2$
Output semicoupling 3	$A_3(-r_{3x}, r_{3y}); B_3(-r_{3x}, -r_{3y}); D_3(0, 0);$ where: $r_{3x} = r_3 \cos \alpha_3$ and $r_{3y} = r_3 \sin \alpha_3$

For the studied mobile transversal coupling multibody model, the generally geometrical restrictions equations are:

$$P_i \equiv P_j, \quad (3)$$

$$\Delta'_2 \equiv \Delta_1, \quad (4)$$

and

$$(x_{P_j} - x_{P_i})^2 + (y_{P_j} - y_{P_i})^2 = l^2. \quad (5)$$

The kinematic restriction equation is

$$\rho_1 - f(t) = 0. \quad (6)$$

Based on the relations (3)...(5), it is obtained an equation system with 9 equations and 9 unknowns:  $x_{01}, y_{01}, \varphi_1, x_{02}, y_{02}, \varphi_2, x_{03}, y_{03}, \varphi_3$ . It results

$$x_{O1} = 0 ; y_{O1} = 0, \quad (7)$$

$$x_{O3} = e_x ; y_{O3} = e_y, \quad (8)$$

$$x_{O2} \sin \varphi_1 - y_{O2} \cos \varphi_1 + r_2 \sin(\varphi_1 - \varphi_2) = 0, \quad (9)$$

$$x_{O2} \sin \varphi_1 - y_{O2} \cos \varphi_1 - r_2 \sin(\varphi_1 - \varphi_2) = 0, \quad (10)$$

$$(x_{P_2} - x_{A_3})^2 + (y_{P_2} - y_{A_3})^2 = l_2'^2 \quad (11)$$

$$(x_{Q_2} - x_{B_3})^2 + (y_{Q_2} - y_{B_3})^2 = l_2''^2 \quad (12)$$

From the relations (9) and (10) result

$$\sin(\varphi_1 - \varphi_2) = 0 \quad (13)$$

Relation (12) led to  $\varphi_1 = \varphi_2 + 2K\pi$ , where  $K \in \mathbb{Z}$ , for  $\forall \varphi_1, \varphi_2 \in \mathbb{R}$ .

For the real case,  $K = 0$ , it is obtained

$$\varphi_1 = \varphi_2 . \quad (14)$$

If the links between the bodies 2 and 3 are equal, then  $l_2' = l_2'' = l_2$ , and from relations (11) and (12) result

$$\begin{cases} r_2'' \cos \alpha_2'' \cos \varphi_2 = r_3 \cos \alpha_3 \cos \varphi_3; \\ r_2'' \cos \alpha_2'' \sin \varphi_2 = r_3 \cos \alpha_3 \sin \varphi_3; \\ \sin(\varphi_2 - \varphi_3) = 0. \end{cases} \quad (15)$$

If  $r_2'' \cos \alpha_2'' = r_3 \cos \alpha_3$  (in fact  $r_{2x}'' = r_{3x}$ , a parallelism condition between the links), the result is  $\varphi_2 = \varphi_3 + 2K\pi$ , where  $K \in \mathbb{Z}$ , for  $\forall \varphi_2, \varphi_3 \in \mathbb{R}$ . For the real case  $K = 0$ , it is obtained

$$\varphi_2 = \varphi_3 . \quad (16)$$

Taking account the relations (14) and (16), it is obtained

$$\varphi_1 = \varphi_3 . \quad (17)$$

The relation (17) is the homokinetism condition of the transversal mobile coupling.

### 3. RESULTS

From the equation system (15), it result the homokinetism condition of the mobile transversal coupling (17). Finally, it is necessary to discuss the equality

$$r_2'' \cos \alpha_2'' = r_3 \cos \alpha_3 \quad (18)$$

If we consider  $\alpha_3$  and  $r_3$  known, it is necessary to obtain  $\alpha_2''$  and  $r_2''$ . It is obtained:

$$\cos \alpha_2'' = \frac{r_3}{r_2''} \cos \alpha_3, \quad (29)$$

for  $\alpha_2'' \in \mathbb{R}$  and  $\frac{r_3}{r_2''} \cos \alpha_3 \in \mathbb{R}$ .

Taking account of the cosinus function properties, the theoretical cases result as follow:

- case 1, figure 3, a, new constructive variant:

$$\alpha_2'' = \pm \alpha_3 + 2K\pi, \quad \text{for } r_3 = r_2''.$$

- case 2, figure 3, b, Oerlikon:

$$\alpha_2'' = 0, \quad \text{for } r_2'' < r_3.$$

- case 3, figure 3, c, new constructive variant:

$$\alpha_2'' = \pm \arccos\left(\frac{r_3}{r_2''} \cos \alpha_3\right) + 2K\pi, \quad \text{for } \frac{r_2''}{r_3} > 1.$$

- case 4, figure 3, d, new constructive variant:

$$\alpha_2'' = \pm \arccos\left(\frac{r_3}{r_2''}\right) + 2K\pi, \quad \text{for } \frac{r_3}{r_2''} < 1 \text{ and } \alpha_3 = 0.$$

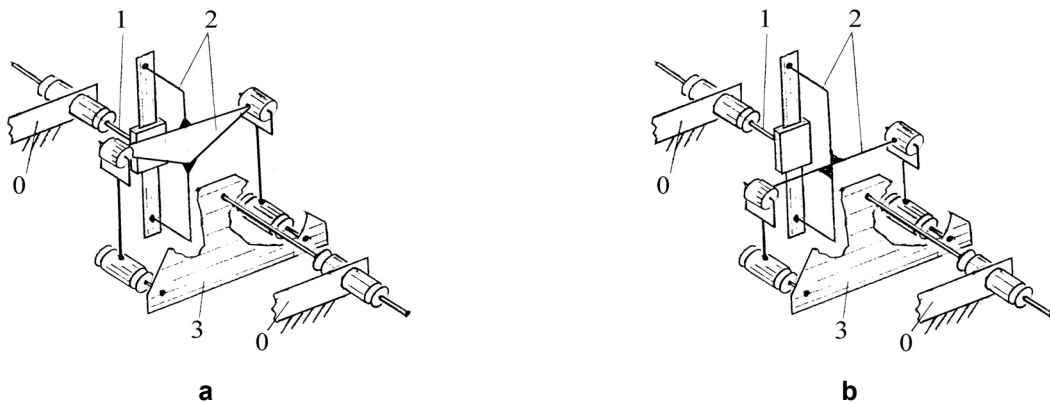

**Figure 3. The homokinetic transversal mobile couplings**

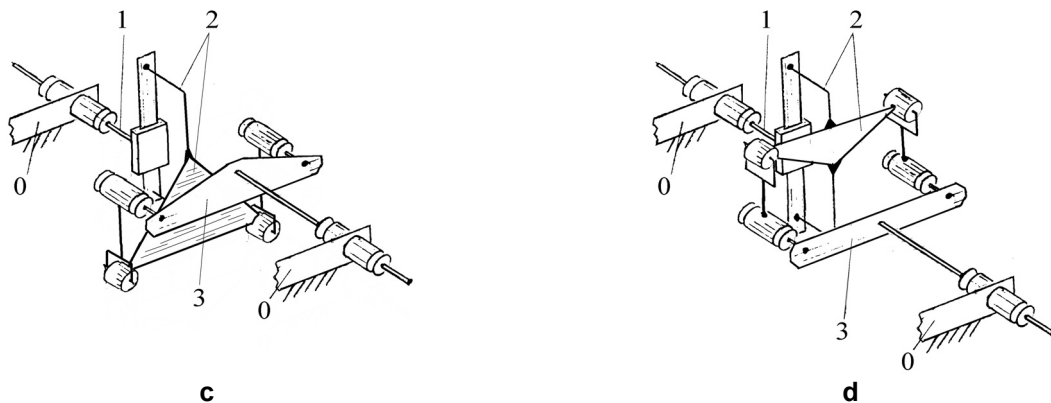

Figure 3. The homokinetic transversal mobile couplings (continued)

## 5. CONCLUSIONS

In the case of the mobile couplings as multibody systems with three bodies, the homokinetism result in two steps: first  $\varphi_1 = \varphi_2$ , and then  $\varphi_2 = \varphi_3$ , according to the conditions relative to the geometry of the bodies. Specifying the coupling constructive conditions is important here, because is useful in coupling's dynamic behavior and in manufacturing process [1, 5].

From this couplings type, there is known and used the Oerlikon coupling. The multibody theory was also useful to discover some new other constructive solutions, from the equation (18).

The method can be applied also for other known mobile couplings, as multibody systems with four or five mobile bodies and for other new solutions of mobile couplings, identified previously by the authors in structural analysis with graphs [4].

In the future researches, the authors intend to analyze these new particular cases and also to find their optimal shape configuration, in the design process.

## REFERENCES

- [1]. Dudiță, Fl., Diaconescu, D., *Cuplaje mobile articulate*. Ed. Orientul Latin, Brașov, 2001.
- [2]. Gavrilă, C.C., *Comparative Kinematics Of Mobile Transversal Coupling, As Multibody System*. Proceedings Of The Second European Conference on Mechanism Science EUCOMES 08, Cassino, Italy, 17-20 September 2008, Springer Science + Business Media B.V. 2009.
- [3]. Gavrilă, C.C., Velicu, R., *Kinematics Of Mobile Transversal Coupling, As Multibody System*, Proceedings of the 6th International DAAAM Baltic Conference "Industrial Engineering", 24-26 April 2008, Tallinn, Estonia.
- [4]. Shigley, J. E., *Kinematic Analysis of Mechanisms*. McGraw-Hill, New York, 1959.
- [5]. Vișa, I., Gavrilă, C. C., *Structural Synthesis Of Transversal Couplings By Multibody Systems Method*, 12th IFToMM World Congress, Besançon, France, June 18-21, 2007, CD-Rom edition.
- [6]. Vișa, I., Alexandru, P., Talabă, D., Alexandru, C., *Proiectarea funcțională a mecanismelor. Metode clasice și moderne* Ed. Lux Libris, Brașov, 2004.