

## AN APPROACH OF THE SIMULATION OF “GREEN LIGHT” IN TRAFFIC USING THE GWTOOL SOFTWARE

**ROMOCEA Sanda<sup>1</sup>, GANEA Macedon<sup>2</sup>, ALBU Adina Aictoria<sup>2</sup>**  
 SC Drumuri Bihor SA, Oradea, [sandaromoccea@yahoo.com](mailto:sandaromoccea@yahoo.com),

**Keywords:** green wave, time cycle, traffic simulation, controller, GWTOOL

**Abstract:** In the urban area, most of the times, the intersections are at relatively small distances one towards the other. Consequently there are cases in which the drivers, who start to roll at the beginning of the green light in an intersection, arrive at the next intersection at the end of the green light. Such situations lead to traffic jams and long periods spent on the public roads. If in the example below, the car arrived at the second semaphorized intersection at the beginning of the green period, the time spent in traffic would be reduced substantially. Such cases are called “green waves”.

### 1. INTRODUCTION

Implementing a new Green Wave means in fact synchronizing and interconnecting several traffic lights. The most used interconnection system is functioning as an identical semaphoring cycle. The semaphores are configured in such way that the lag between each of them is calculated considering the distance between the stop lines. These semaphoring moments can be established through the “time distance diagram”:

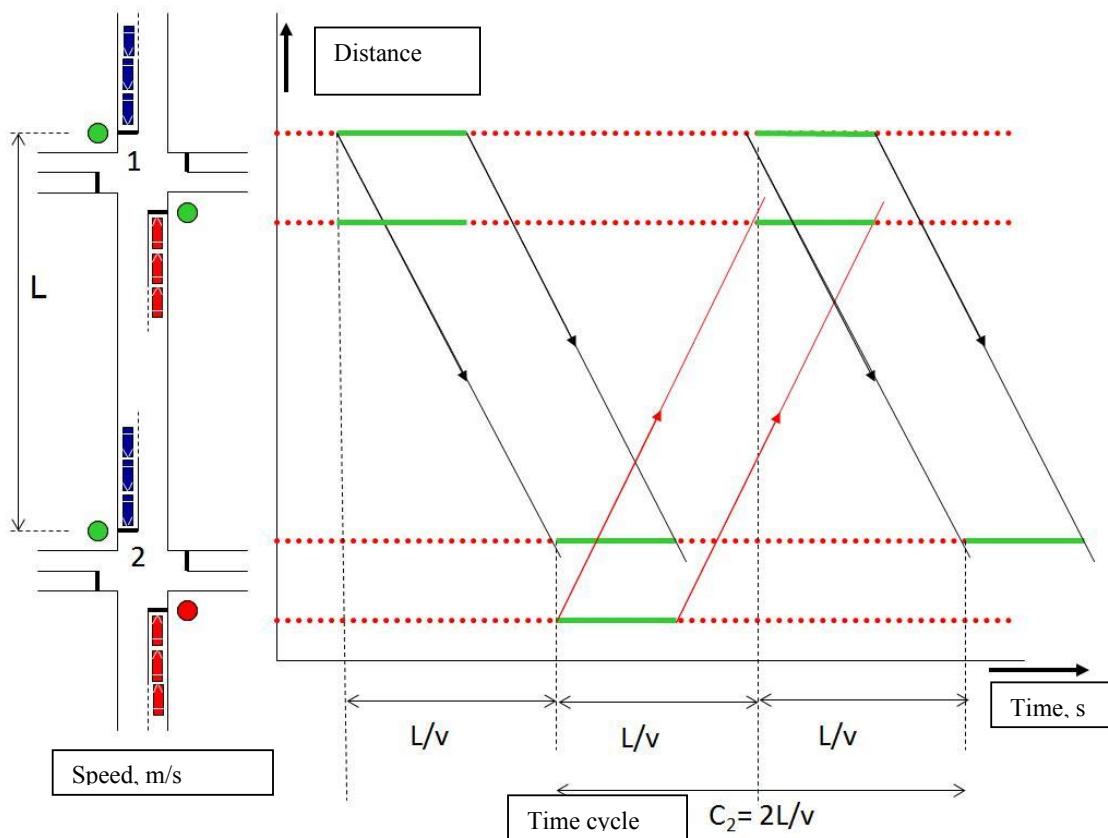

**Fig. 1 –An example of time -distance diagram**

The active itinerary is marked on axis “Y” and the travel time is marked on the axis “X”. The diagonal lines represent the movement of a car at a certain speed (V) which arrives at the second intersection in the time L/V. If only two intersections are in discussion, we can

notice that we have the exact same situation for the opposite lane, so we can talk about a perfect green wave with a  $2L/V$  cycle.

This presentation is purely theoretical because in reality there is a sum of factors, which influence the traffic flow, fact that can lead to defective green waves in which several conflict areas are found. However, even though, the distance  $L$  between the intersections and the speed  $V$  of the motor vehicles are the main factors, which lay at the basis of the good accomplishment of semaphoring moments (cycle times), and the formula used for calculating the times of a cycle is a starting point for the accomplishment of one "green wave":

$$C = 2L/V$$

Another important factor is the duration of the green light of a semaphoring cycle, which must be long enough as to allow all the vehicles to exit the intersection during the green light of the semaphore. If this situation does not materialize there will appear traffic jams even if these semaphores are synchronized on green wave. It is very important to bear in mind that the synchronization of the semaphores inside a green wave system can improve the traffic flow on a certain section of the road, but when that section becomes crowded above the normal level (rush hours) the green wave system cannot produce any kind of improvements.

If inside a green wave system there are more than 2 intersections, then the formula above related to the cycle time must be used for each intersection as it is presented in the figure below.

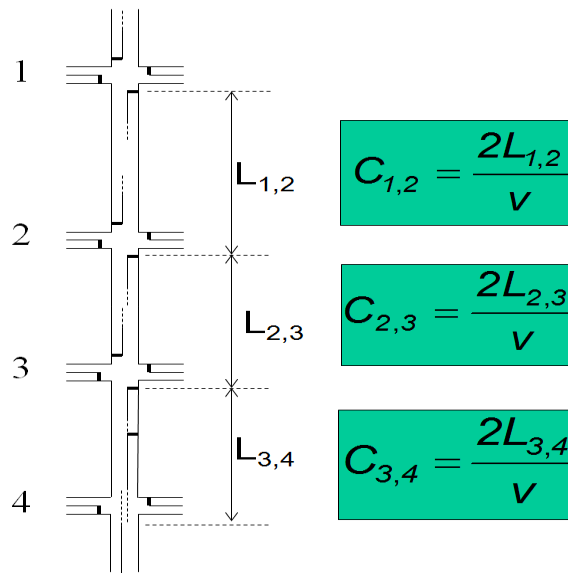

**Fig. 2 – Discretization the cycle time on intersections**

In this example the distances between the intersections are equal ( $L_{1,2} = L_{2,3} = L_{3,4}$ ) but in reality this thing is impossible, therefore a perfect green wave cannot be realized, the real applications being forced to resort to compromises. No matter the case, the semaphoring cycles must be the same.

Other aspects, which must be taken into consideration when a green wave is realized, can be as follows:

In the best situation all the vehicles have the same speed, but in reality the drivers act differently, the dilution effect of the vehicles group in traffic making its appearance. This

means that the distance between cars increases in proportion with the distance traveled through by the cars;

Pedestrian crossing without semaphoring or synchronization, which forces the vehicles to slow down or even stop;

The stopped vehicles will not be able to roll at the optimal speed immediately after they started rolling out the intersection therefore arriving later at the next intersection;

The vehicles that stop at the red light in such situations will block the traffic that comes from the auxiliary roads;

Another perturbation of the green waves is represented also by the left turns, because these can produce jams on one of the road's lanes.

## 2. LAUNCHING OF THE APPLICATION

The GWTOOL software is a PC application, which realizes the time distance diagram for consecutive intersections.

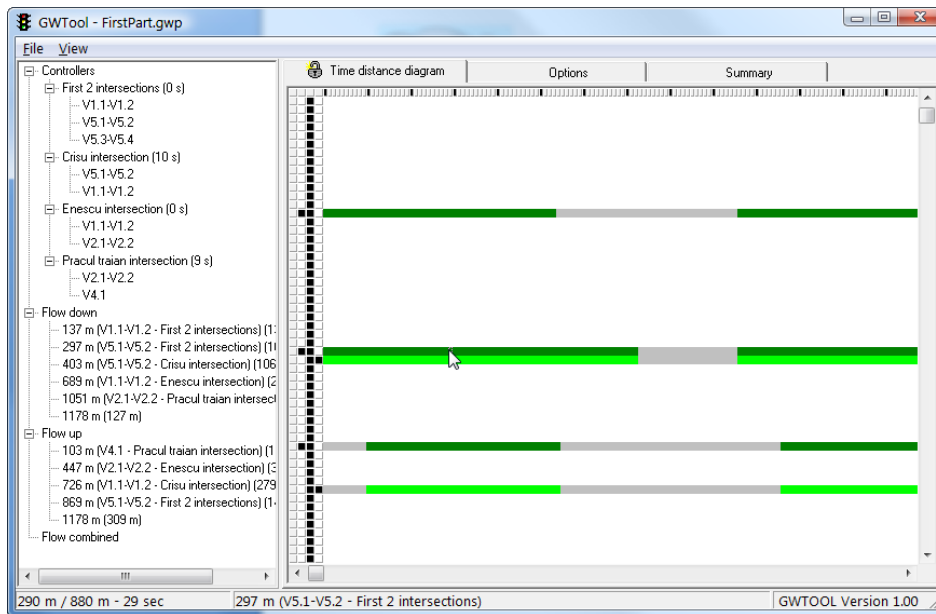

**Fig. 3 – Starting GWTOOL, graphical user interface**

Defining some of the concepts:

**Controller:** it's the device, which controls the semaphoring cycles for the different flows, usually inside an intersection.

**Lights:** it's the electronic display of the semaphoring cycles connected to a controller, identifying the *green* period for the respective flow.

**Flow down – Flow up:** it is a representation of the flows of a road on a certain section of the road with a distance  $L$  and a medium speed  $V$ .

**The time distance diagram:** it's a representation of the driving time (Axis X) of a vehicle on a road segment (Axis Y). The installation of the program summarizes up to copying the file GWTOOL.EXE anywhere on the hard disk of the computer. The application starts by a double click on the program GWTOOL.EXE.

On the left side of the previous image the controllers, the two flows, and the combination of those two are described under the form of source – branches. On the right side, the time distance diagram is represented, which in the end can be used for optimizing the green wave.

**The Menu**

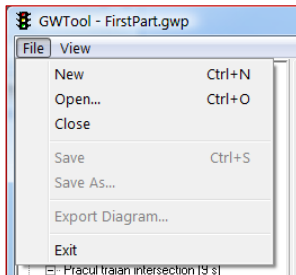

The Menu button on the upper left side of the program offers the following options:

**New:** creating a new, “gwp” type of document

A “gwp” document contains data related to controllers and time lags, the period of the green light, meaning the flow of an intersection, which had been introduced in the program. Such document is saved on the hard disk having the extension “gwp”. It is a file with XML formatting which should not be edited manually.

**Open:** a folder “gwp” is selected from a certain location, such as the hard disk, in order to upload the data that it contains in the program GWTOOL.

**Close:** the previously opened document closes. After this operation another file must be opened in order to use the program in the future.

**Save and Save as:** saves the document with the data introduced in the hard disk inside the indicated folder.

**Export Diagram:** allows the saving of the time distance diagrams in image type files in order to use them more easily in some reports or presentations.

**Exit:** closes GWTOOL program.

The “view” menu contains the following options:

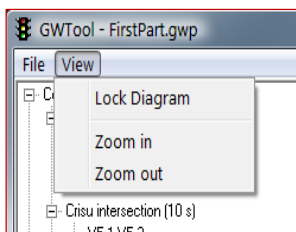

**Lock diagram:** normally, if a controller or a semaphore is selected from the hierarchic branches presentation, the time distance diagram (the drawing on the right side of the main window) modifies in relation with the selection made on the left side (the controllers’ area). If the option **Lock diagram** is used, the drawing on the right side of the main window will not be modified. This option is a switch type option, which means that in the moment of choosing it, the time distance diagram turns back

to its initial setting.

**Zoom in and Zoom out:** it will adjust the diagram to the parameters desired by you.

**3. DEFFINING OF CONTROLLERS AND SEMAPHORES**

In order to accomplish this operation, it is necessary to have created before a new document or to have selected an already existing “gwp” type document using the option “Open.” By right clicking on the option “Controller” we can choose “Add Controller” in order to create a new controller. On the bottom side of the controllers display the specifications of the newly created controller can be introduced:

**Name:** the name of this controller. Usually the name of the intersection is used.

**Cycle time:** the semaphoring cycle of the controller is introduced (in seconds).

**Offset:** the time lag related to a reference time.

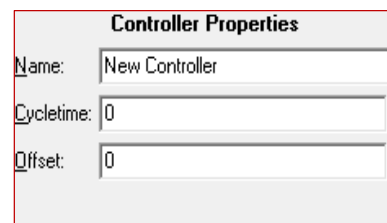
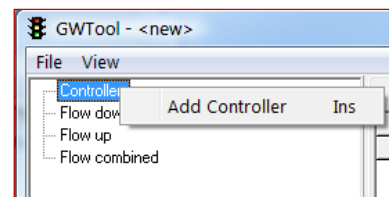

The new types of controllers are using a GPS system in order to have time reference whereas the older types have an internal watch. For having the exact value of such a controller (old) the time distance from the start of the green light of the semaphore in question and the starting point of another semaphore, situated before or after, can be measured, and the time difference represents the time lag that, in this case, will be introduced manually.

In order to erase a controller we can right click on this one and select “delete controller.”

After the controller has been created the afferent semaphores can be added. Right click on the controller and select “Add light” in order to add a semaphore. Down the controllers’ column there will appear a field where the data related to this semaphore can be introduced as follows:

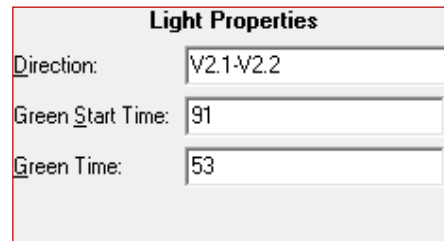
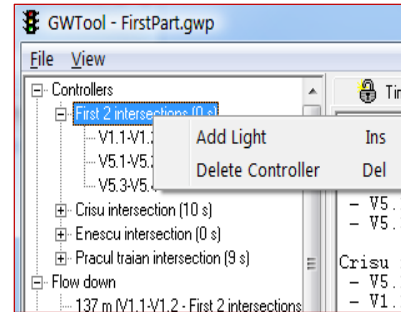

**Direction:** a representative name is given to the flow. Usually the references from the controllers diagrams or other technical drawings are used in this situation.

**Green start time:** the starting second of the green light is introduced in conformity with the data of the controller’s diagrams.

**Green time:** the actual green light duration (in seconds).

Once we introduce the green light moments afferent to the different semaphoring, for all the flows that are important for the Green Wave, we can select: the controller on the right side of the program (the controllers area) in order to obtain the next diagram of the controller:

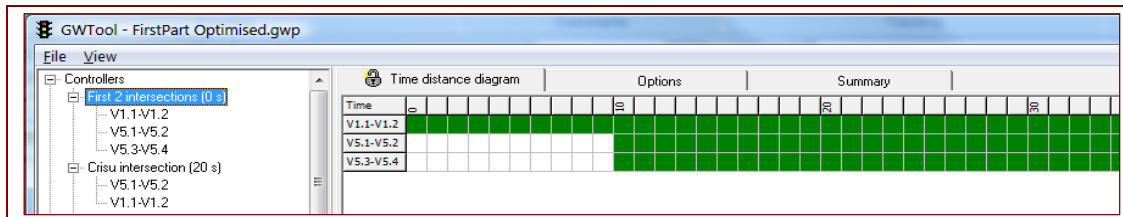

**Fig.4 – Setting-up the controllers**

A set of tables can be obtained from the different controllers with their afferent semaphores and their green light moments, from the tab “summary”:

### 3. CONCLUSIONS

By developing of this software one could approach a different direction on vehicles flow settings management. This work shows there’s one more opportunity to solve the crowding of urban roads. As second conclusion, using of this software, which request, in order to make personalized settings, not advanced knowledge, will be a tool for technicians after the parameters and vehicles flow data will be done. The flow parameters calculus depends on much variable data, so this operation is’nt solve, at this moment, by the software developed and presented here. As future goal, this operation will be included on this software tools. As final conclusion, one may see, the parameters set up on this

software require, to the user, proficiency on manipulating functionals and waiting strings theory, besides, this is more sensitive competence of the road vehicles flow manager.

### **Bibliografy**

- [1]. **Eschelbeck, G., Th. Moser**, *Distributed Traffic - Monitoring and Evaluation by Means of a Client - Server Architectures*. The 13<sup>th</sup> World Computer Congress 94 IFIP.
- [2]. **Florea , D.** – Managementul traficului rutier , Ediția a II –a , completata, Editura Universității Transilvania din Brașov,2000.
- [3]. **Ghiță, C. și colab.**, -*System Software for Automotive in Traffic Localization and Monitoring*, Proceedings of the ECAI07 on ELECTRONICS, COMPUTERS and ARTIFICIAL INTELLIGENCE, 2007.
- [4] **Gonzales, R. C., Woods, R. E.**: Digital Image Processing, Addison Wesley, Reading, MA, 1992.
- [5] **Iliescu, M., Roib, V.**, Applying a Management Computer Software Program Based on Traffic Parameters for Traffic Monitoring, Acta Technica Napocensis, 2008.
- [6] **Jain, A. K.**- Fundamentals of Digital Image Processing, Prentice Hall, Englewood, Cliffs NJ, 1989.
- [7] **Ioniță, A., și colab.**- *An Approach For Urban Road Traffic Management As Application Of Spatial Data Infrastructures*, "A 3-a conferinta dedicata infrastructurii nationale de date spatiale", Bucuresti, 11 -12 decembrie 2008. <http://sdi08.rosa.ro/>.
- [8] **Yosida, T., Kurada, H., Nishigaito, T.** - Adaptive Drive –assistance systems.
- [9] **Zafiu, A, Ghiță, C.**- *An efficient model for traffic simulation*, Advanced in Applied Mathematics, Systems, Communications ans Computers Conference, June 1 – 3, 2008, Maraton Beach, Attica, Greece, ISSN 1790- 2769, ISBN 978-960-6766.
- [10] **Nemțanu, F.C., Minea, M., Burețea, D.L.** - „*The Intelligent Transportation Systems and Services (ITS), a Main Component of Information Approach of Society: The Development of the ITS on a National ITS Architecture* ” Proceedings of ICCS 2004 (International Conference on Computers and Communications) – University of Oradea, Băile Felix, 27-29 Mai 2004.
- [9] **Gonzales, R. C., Woods, R. E.**: Digital Image Processing, Addison Wesley, Reading, MA, 1992
- [10] **Iliescu, M., Roib, V.**, Applying a Management Computer Software Program Based on Traffic Parameters for Traffic Monitoring, Acta Technica Napocensis, 2008.
- [11] **Jain, A. K.**- Fundamentals of Digital Image Processing, Prentice Hall, Englewood, Cliffs NJ, 1989
- [13] **Ioniță, A., și colab.** - "*An approach for intelligent decision support system for urban traffic monitoring*", in Proc of. "Urban and Regional Data Management" – UDMS Annual 2009, Ljubljana, Slovenja, 24 – 26 iunie 2009, Eds. Alenka Krek, Massimo Rumor, Sisi Zlatanova, Elfriede Fendel, CRC Press Taylor & Francis Group – A BALKEMA BOOK, ISBN: 978-0-415-55642-2, ISBN: 978-0-203-86935-2.
- [\*\*\*] **User Manual GWTOOL**