

THEORETICAL STUDY OF THE TORSION BAR OF WEAVING MACHINE

VIGARU Cosmina, LUCA Gheorghe

Politehnica University of Timisoara, Faculty of Mechanical Engineering
cosmina.vigaru@mec.upt.ro; gheorghe.luca@mec.upt.ro

Keywords: torsion bar, weaving machine, pulsation

Abstract The aim of this paper is to create some models for theoretical and experimental studies of weaving machines vibrations. The theoretical study was developed for the torsion bar mechanism. The role of the launch mechanism is to confer to the bullet the kinetic energy required to cross the shed which has a variable length, depending on the number of simultaneous weavings. A particularity of this launching mechanism resides in the fact that the energy required to accelerate the bullet is created by twisting an axle, which, once loaded with potential torsion energy is capable to release this energy and transfer it to the bullet, through the launching arm, [2].

The torsion bar was modeled by two parts and the proper pulsation was theoretically calculated. The model of torsion bar was also analyzed using numerical methods. In that case were determinate the proper pulsation and natural mode of vibration.

1. INTRODUCTION

The role of the launch mechanism is to confer to the bullet the kinetic energy required to cross the shed which has a variable length, depending on the number of simultaneous weavings.

A particularity of this launching mechanism resides in the fact that the required energy to accelerate the bullet is created by twisting a torsion bar, which, once loaded with potential torsion energy is capable to release this energy and transfer it to the bullet, through the launching arm.

In the case of weaving machine is difficult to establish every source of vibration. In weaving process all mechanism are working in the same time and generate vibration.

The most important source of vibration is: the slay, the launching mechanism and the mechanism for moving the warp yarn.

2. THEORETICAL STUDY OF TORSION VIBRATION

For the torsion bar where establish two references systems x_1 and x_2 with the origins O_1 and O_2 which are presented in Fig.1.



Figura 1 Torsion bar

The differential equation of the torsion vibrations is, [1]:

$$\frac{\partial^2 \varphi}{\partial x^2} - \frac{J}{G \cdot I_p} \cdot \frac{\partial^2 \varphi}{\partial t^2} = - \frac{M_{t_0}(x, t)}{G \cdot I_p} \quad (1)$$

and for the free undamped vibrations:

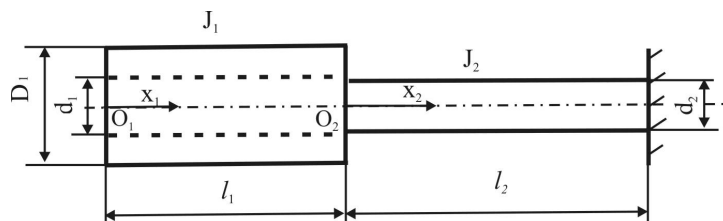
$$\frac{\partial^2 \varphi}{\partial x^2} - \frac{J}{G \cdot I_p} \cdot \frac{\partial^2 \varphi}{\partial t^2} = 0 \quad (2)$$

The expected form of harmonic solutions is:

$$\varphi(x, t) = \varphi_0 \Phi(x) \sin(p t + \theta) \quad (3)$$

where: $\Phi(x)$ is the proper function. If the solution (3) verifies the differential equation (2) the proper function equation was obtained:

$$\frac{d^2 \Phi(x)}{dx^2} + \alpha^2 \cdot \Phi(x) = 0 \quad (4)$$

where:

$$\alpha^2 = p^2 \cdot \frac{J}{G \cdot I_p} \quad (5)$$

The proper functions for the two parts of the bar are expected to be as follows:

$$\begin{aligned} \varphi_1 &= C_1 \sin \alpha x_1 + C_2 \cos \alpha x_1 \\ \varphi_2 &= C_3 \sin \alpha x_2 + C_4 \cos \alpha x_2 \end{aligned} \quad (6)$$

The limit conditions are [3]:

$$\begin{aligned} \left. \frac{d\varphi_1}{dx_1} \right|_{x_1=0} &= 0 \\ \varphi_2 \Big|_{x_2=l_2} &= 0 \end{aligned} \quad (7)$$

and the conditions of continuity are:

$$\begin{aligned} \varphi_1 \Big|_{x_1=l_1} &= \varphi_2 \Big|_{x_2=0} \\ G I_{p_1} \left. \frac{d\varphi_1}{dx_1} \right|_{x_1=l_1} &= G I_{p_2} \left. \frac{d\varphi_2}{dx_2} \right|_{x_2=0} \end{aligned} \quad (8)$$

It results:

$$\begin{aligned} C_1 &= 0 \\ C_3 \sin \alpha_2 l_2 + C_4 \cos \alpha_2 l_2 &= 0 \\ C_1 \sin \alpha_1 l_1 + C_2 \cos \alpha_1 l_1 &= C_4 \\ G I_{p_1} (\alpha_1 C_1 \cos \alpha_1 l_1 - \alpha_2 C_2 \sin \alpha_1 l_1) &= G I_{p_2} \alpha_2 C_3 \end{aligned} \quad (9)$$

In order that the system to admit solutions, different of the null solution for C_2, C_3, C_4 , the determinant must be null:

$$\begin{vmatrix} 0 & \sin \alpha_2 l_2 & \cos \alpha_2 l_2 \\ \cos \alpha_1 l_1 & 0 & -1 \\ -I_{p_1} \cdot \sin \alpha_1 l_1 & -I_{p_2} & 0 \end{vmatrix} = 0 \quad (10)$$

It results:

$$\operatorname{tg} \alpha_1 l_1 \cdot \operatorname{tg} \alpha_2 l_2 = \frac{l_{p2}}{l_{p1}} = \frac{d_2^4}{D_1^4 - d_1^4} = 0.146 \quad (11)$$

From relation (5) and (11) result:

$$\operatorname{tg} \left(p \sqrt{\frac{J_1}{G l_{p1}}} l_1 \right) \cdot \operatorname{tg} \left(p \sqrt{\frac{J_2}{G l_{p2}}} l_2 \right) = 0.146 \quad (10)$$

Solving the equation (10) the proper frequency result $p_1=2359$ rad/s.

3. STUDY OF TORSION BAR VIBRATION USING NUMERICAL METHODS

The model of torsion bar is presented in figure 2.



Figura 2 The model of torsion bar

The proper pulsation and the shape mode are presented in figure 3.

By analyzing the mode shape, results that the torsional vibration appears for frequencies: $f_3 = 365.248$ Hz and $f_6 = 927.054$ Hz. The fundamental pulsation obtained by analyzing the torsion bar with numerical method was: 2238 rad/s.

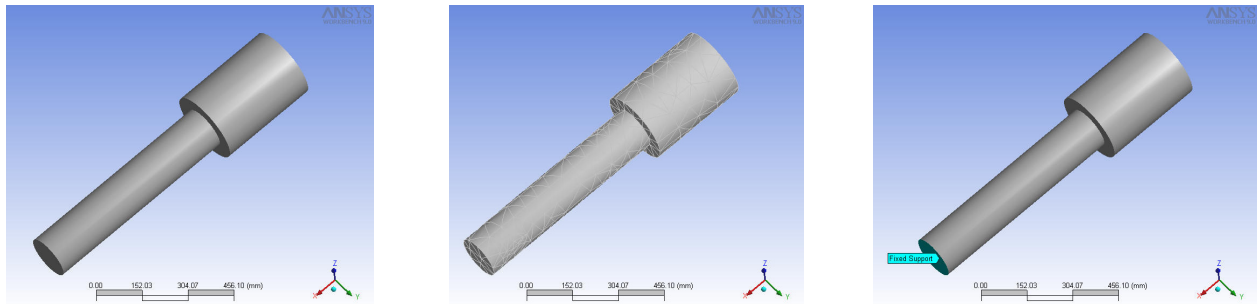
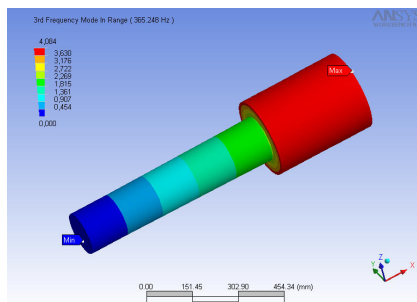

f3=365.248 Hz

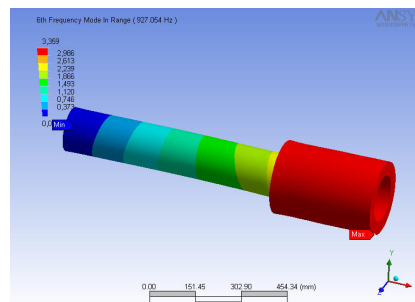

f6=927.054 Hz

Figura 3 The mode shape of vibration and the corresponding frequencies

4. Conclusion

By analyzing the mode shape, results that the torsional vibration appears for frequencies: $f_3 = 365.248$ Hz and $f_6 = 927.054$ Hz. The pulsation obtained by analyzing the torsion bar with numerical method was: 2238 rad/s and 5824.82 rad/s. The fundamental pulsation obtained using Ansys are $p_{\text{Ansys}}=2238$ rad/s.

The fundamental pulsation obtained with the exact method is $p_1=2359$ rad/s.

Comparing these values (fundamental pulsation obtained using the numerical method and fundamental pulsation obtained using exact method) a difference of 5.4% was computed.

REFERENCES

- [1] Buzdugan Gh., Fetcu L., Radeş M.,- Vibrații mecanice, Ed. Didactică și Pedagogică, București, 1979
- [2] Luca Gh., Vigaru.C. Chiriac A., Study of Vibration at the Lauching Mechanism of the Sulzer Weaving Machine, Studia Universitatis „Vasile Goldiș”, 2006. Seria Științe inginerești și agro-turism, ISSN 1842-0508, pag.265-272.
- [3] Luca Gh., Drăgulescu D., Ștefan C., Tulvan D., Contributions concerning the transversal vibrations of a bars with application in textile industry, 2-nd International Conference Research and development in mechanical industry, Radmi 2002, Proceedings, vol.2, pg.928-935, Vrujacka Banja, Yugoslavia, 01-04 september 2002.