

PROPOSED STRUCTURE OF FLEXIBLE MANUFACTURING SYSTEM FOR TMA 55 MILLING MACHINE

CSOKMAI Lehel Szabolcs, GANEA Macedon
University Of Oradea
lcsokmai@uoradea.ro

Keyword: flexible manufacturing. Flexible cells, production, systems

Abstract: The 55 OPN by TMA f.a.s S.p.A. is a machining center with horizontal axis designed to accomplish mechanical processes such as milling, reaming, drilling and tapping on medium sized work pieces for which it is essential to ensure accurate machining, fast operation, easy positioning and economic production. The standard versions of 55 OPN are built with reliable, economical and easily serviced components.

The 55 OPN by TMA f.a.s S.p.A. is a machining center with horizontal axis designed to accomplish mechanical processes such as milling, reaming, drilling and tapping on medium sized work pieces for which it is essential to ensure accurate machining, fast operation, easy positioning and economic production.

The standard versions of 55 OPN are built with reliable, economical and easily serviced components.

The oversized and reinforced structure is cast in stress relieved G26 cast iron with high mechanical characteristics and enbloc sideways hardened to 840 Brinell.

The sideway backings are covered in anti-friction material (TURCITE) and are perfectly coupled to the respective sideways by hand-scraping operations.

When movement of the axes was designed, priority importance was given to rigidity and, consequently, the life and accuracy of the machine.

High quality ball screws have been used for the moving parts. These have double preloaded nuts and are mounted on high precision oblique contact bearings.

Drive is supplied by variable speed motors which transmit this to the ball screws through positive timing belts with high power transmission characteristics while requiring no maintenance. Transmission belt tension is adjusted by moving the support plates on which the motors are mounted.

Rotary spindle movement is achieved by a variable speed motor mounted at the rear and with shaft parallel to the spindle. Drive is transmitted by a timing belt featuring high power transmission and requiring no maintenance.

On request, the machine can be fitted with a 2-speed gearbox managed by the NC and enabling optimum use of power at different rpm rates.

The tool holder spindle consists of a removable cartridge element with long-lasting grease-lubricated precision bearings possessing a high load capacity, max. speed 4500 rpm. Cartridge construction of the spindle enables easy demounting from outside for checks or replacements in the case of faults.

The automatic spindle positioning system is standard supply on our machines. Programmed positioning managed by the NC is ensured by the angular positioner mounted with its axis parallel to the spindle and at the end of this. It is driven by means of two pulleys 1 with timing belt, ratio 1:1, to ensure that the spindle and angular positioner operate at the same rpm rate.

Operation of the spindle positioner is essential both during the change phase and when the machining process requires entry into a recess or to disengage the tool during the return phase after reaming and with the tool itself at a standstill.

Automatic tool clamping is achieved by means of Belleville washers which exercise a tension of about 800 Kg on the draft clamp which, coupling the relative tool tang rod, holds the entire unit to the spindle cone. Besides the spring load, the entire system is held in a position of maximum rigidity by an irreversible taper device held in place by an internal pawl acting as an expansion wedge unclamping phase. During its travel, the bar of the hydraulic cylinder disengages the safety device, compresses the holding springs thus allowing the clamp to open and freeing the pawl. At this point, the tool holder can be removed both automatically and manually.

Clamping phase.

Clamping is accomplished by automatically or manually inserting the tool holder into the spindle cone (with the clamp open). By reversing the oil flow during loading, the springs are able to expand, clamp the tool holder and enable the safety load during final travel:

- During automatic cycle, the clamping and unclamping operations are automatically synchronized with the tool removing unit
- In manual mode, the cycle is enabled by means of the relative push button

The internal device which flushes the tool holder spindle housing starts operating when the tool unclamping cycle starts and remains active until the spindle clamping phase terminates.

The machine is equipped with a balancing system to prevent the spindle head from unnecessarily stressing the Y movement ball screw, thus jeopardizing both accuracy and machine life. This is a hydraulic system supplied by the service plant which, by means of a pressure metering valve and a balancing valve, supplies more or less oil to the balancing cylinder of Y axis.

An accumulator keeps the pressure of the oil in the circuit at a steady value and compensates the displacement variations due to temperature changes. The working pressure of the system is 20-22 bar and can be checked on the relative pressure gauge. Oil is loaded into the system and drained by the ball cock.

Machining center 55 OPN includes a tool magazine of the chain type with capacity of 32 or 64 places for DIN 69871 cones.

It consists of:

- a system with vertical structure to house the fixture and programmed tool search
- a change system which takes the tool from the magazine, changes it with the one previously mounted on the spindle and replaces the exchanged tool on the chain magazine.

The following paragraphs describe the various parts forming both the tool magazine and the control devices.

Composition:

- Base of the structure (for a 64 position magazine)
- Support column
- Chain-type tool magazine
- Hydraulic mechanism for tool change

The tool holder chain is operated by a toothed driving pinion (3 for transmission with 64 tools - 1 for transmission with 32 tools). Operation is controlled by a variable speed electric motor directly coupled to an rpm reduction unit in order to optimize the operative speed of the tool holder chain.

A control system consisting of a micro switch and a resolver detects the position and chooses the correct tool programmed for the machining process in question.

The former is controlled by a cam on the tool holder chain and enables initial zero-setting when the machine is powered. Coupled to the driving pinion, the resolver detects the

correct angular position of the pinion itself and, consequently, the correct position of the selected tool.

There is a positioning pin to maintain this position against possible movements of the tool holder chain. This is controlled by solenoid valve and holds the chain in the correct position. The movement of this positioning pin is monitored by proximity switches.

Presence of the tool in the change zone between the magazine and manipulator is detected by a proximity switch which transmits the cone present message to the control unit in order to prevent collisions between two tools.

The device is released by a hydraulic release cylinder also driven by solenoid valve and monitored by a sensor in the ENGAGED-DISENGAGED positions.

Since machining center 55 OPN by TMA f.a.s. S.p.A. possesses high technological characteristics, basic machine configuration also includes a pallet store with relative manipulator to load and unload the table from the machining area and bracket in position away from this area thus ensuring safe conditions for the operator and rapid accomplishment of the operation itself.

Management of the pallets in the store is directly monitored by the C.N.C. program.

Hydraulic power for these systems is supplied by the main hydraulic plant at a working pressure of 42 bar. Fixed on the front part of the machine in axis with the tool holder spindle, the pallet store mainly consists of:

- A base fixed to the floor. This bears a rotating circular structure supporting the various pallets by means of a large bearing enbloc with a ring gear
- Store driving unit consisting of a variable speed motor and an rpm reduction unit which acts on the ring gear. All these parts are monitored by a zero limit switch and a resolver (which meshes on the ring gear by means of a special gear with "zero" play) to handle correct store positioning.
- A hydraulic cylinder to load and unload the pallets, enbloc with the basic structure.

The pallet loading and unloading station has been specially designed to optimize bracketing times and preparation of the work piece for the machining phase. It can turn the pallet table through 360, enabling the operator to bracket in the best possible way.

The position of the loading station can be established by the customer.

In particular and unlike other types, the pallet bracketing station includes a pneumatic cylinder. This has a coupling at the top of its stem which, controlled by solenoid valve, disengages the locking pin and enables pallet holder rotation.

There is a safety micro switch which prevents all pallet store movements when the locking pin is not in its housing.

The pallet holder unclamping control is situated on the push button panel.

The electrical and electronic component of the machine is housed in the cabin situated in a separate position beside the machine and contains the following electrical and electronic parts:

- C.N.C. numerical control
- Axes drive control unit
- Electrical power pack (power transformers) to supply all machine services
- Memory battery with recharge for C.N.C. memory upkeep
- Thermals and remote control switches

The following flexible manufacturing system will be built.

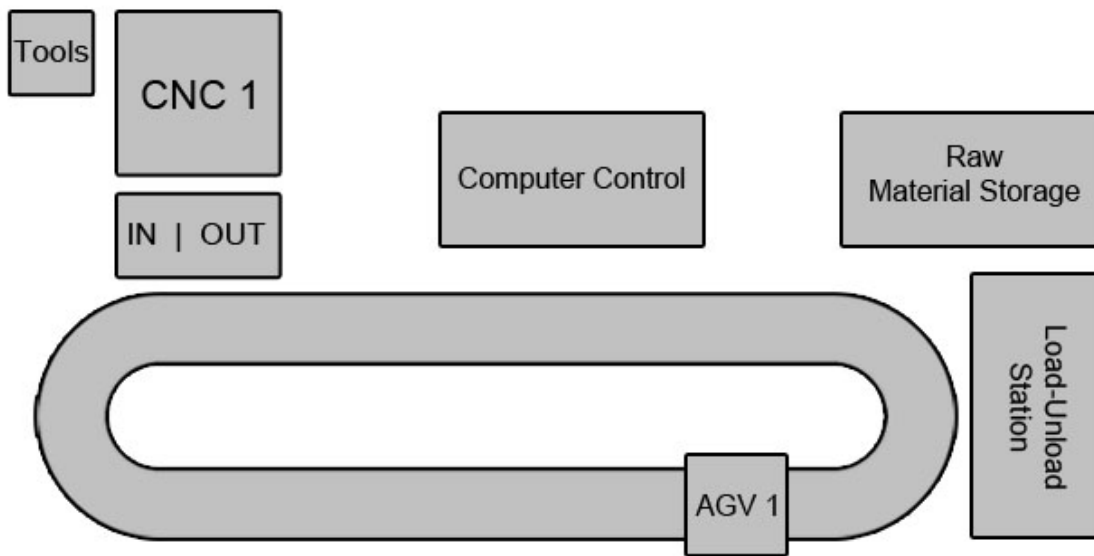

Figure 1 Flexible manufacturing system with 55 OPN

The components of the system are:

- Automated material handling and storage system
- Computer control
- Conveyor
- 55 OPN C.N.C. machine.

References:

- [1]Abrudan, I. (1996). *Sisteme flexibile de fabricatie. Concepte de proiectare si management*. Cluj-Napoca: Editura Dacia.
- [2]Andrea, M. (2005). *Design of Advanced Manufacturing Systems*. Torino: Springer.
- [3]Barabas T., V. T. (1997). *Mașini unelte și agregate*. Oradea: Editura Universitatii din Oradea.
- [4]Boncoi, G. (2000). *Sisteme de productie, vol.I. Concepte și automatizari*. Brasov: Editura Universitatii Transilvania.
- [5]Brandl, D. (2006). *Design patterns for flexible manufacturing*. ISA—Instrumentation, Systems, and Automation Society.
- [6]Catrina, D. s. (1994). *Sisteme flexibile de prelucrare prin aschiere, vol.II*. Bucuresti: Unoversitatea Politehnica Bucuresti.
- [6]Călin, S. P. (1988). *Conducerea adaptivă și flexibilă a proceselor industriale*. Bucuresti: Editura Tehnica.
- [7]Francisc W. Kovacs, R. C. (1999). *Sisteme de fabricație flexibilă* . Oradea: Editura Universitatii din Oradea.
- [7]Ganea, C. (1998). *Particularitati tehnologice privind prelucrarea pieselor* . Universitatea Tehnica Cluj-Napoca.
- [8]Ganea, M. (2009). *Masini unelte flexibile si echipamente tehnologice pentru prelucrarea pieselor prismatice*. [9]Oradea: Editura Universitatii din Oradea.
- [10]Ganea, M. (2010). *Mașini unelte și sisteme flexibile*. Oradea: Editura Universitatii din Oradea.
- K[11]ovacs, F. G. (1988). *Sisteme de fabricație flexibilă robotizate, vol.I,II*. Timisoara: Litografia Universitatea Tehnică Timișoara.
- [12]Mihaila, I. (1987). *Tehnologia Fabricarii Masinilor*. Oradea: Institutul de Subingineri Oradea.
- [13]Youssef, H. A. (2008). *Machining technology : machine tools and operations*. CRC Press.